

Flanges and their joints — Gaskets for PN-designated flanges —

Part 2: Spiral wound gaskets for use with steel flanges

The European Standard EN 1514-2:2005 has the status of a
British Standard

ICS 23.040.80

National foreword

This British Standard is the official English language version of EN 1514-2:2005. It supersedes BS EN 1514-2:1997 which is withdrawn.

The UK participation in its preparation was entrusted to Technical Committee PSE/2, Jointing Materials and Compounds, which has the responsibility to:

- aid enquirers to understand the text;
- present to the responsible international/European committee any enquiries on the interpretation, or proposals for change, and keep the UK interests informed;
- monitor related international and European developments and promulgate them in the UK.

A list of organizations represented on this committee can be obtained on request to its secretary.

Cross-references

The British Standards which implement international or European publications referred to in this document may be found in the *BSI Catalogue* under the section entitled “International Standards Correspondence Index”, or by using the “Search” facility of the *BSI Electronic Catalogue* or of British Standards Online.

This publication does not purport to include all the necessary provisions of a contract. Users are responsible for its correct application.

Compliance with a British Standard does not of itself confer immunity from legal obligations.

Summary of pages

This document comprises a front cover, an inside front cover, the EN title page, pages 2 to 14, an inside back cover and a back cover.

The BSI copyright notice displayed in this document indicates when the document was last issued.

Amendments issued since publication

Amd. No.	Date	Comments

This British Standard was published under the authority of the Standards Policy and Strategy Committee on 28 June 2005

© BSI 28 June 2005

ISBN 0 580 46100 9

English version

Flanges and their joints - Gaskets for PN-designated flanges -
Part 2: Spiral wound gaskets for use with steel flanges

Brides et leurs assemblages - Joints pour les brides
désignées PN - Partie 2: Joints spiralés pour utilisation
avec des brides en acier

Flansche und ihre Verbindungen - Dichtungen für Flansche
mit PN-Bezeichnung - Teil 2: Spiraldichtungen für
Stahlflansche

This European Standard was approved by CEN on 24 March 2005.

CEN members are bound to comply with the CEN/CENELEC Internal Regulations which stipulate the conditions for giving this European Standard the status of a national standard without any alteration. Up-to-date lists and bibliographical references concerning such national standards may be obtained on application to the Central Secretariat or to any CEN member.

This European Standard exists in three official versions (English, French, German). A version in any other language made by translation under the responsibility of a CEN member into its own language and notified to the Central Secretariat has the same status as the official versions.

CEN members are the national standards bodies of Austria, Belgium, Cyprus, Czech Republic, Denmark, Estonia, Finland, France, Germany, Greece, Hungary, Iceland, Ireland, Italy, Latvia, Lithuania, Luxembourg, Malta, Netherlands, Norway, Poland, Portugal, Slovakia, Slovenia, Spain, Sweden, Switzerland and United Kingdom.



EUROPEAN COMMITTEE FOR STANDARDIZATION
COMITÉ EUROPÉEN DE NORMALISATION
EUROPÄISCHES KOMITEE FÜR NORMUNG

Management Centre: rue de Stassart, 36 B-1050 Brussels

Contents

	Page
Foreword.....	3
Introduction	4
1 Scope	5
2 Normative references	5
3 Terms and definitions	5
4 Designations	5
5 Gasket designs	7
6 Gasket types.....	8
7 Dimensions.....	8
8 Marking	11
Annex A (informative) Information to be supplied by the purchaser.....	13
Bibliography	14

Foreword

This European Standard (EN 1514-2:2005) has been prepared by Technical Committee CEN/TC 74 "Flanges and their joints", the secretariat of which is held by DIN.

This European Standard shall be given the status of a national standard, either by publication of an identical text or by endorsement, at the latest by November 2005, and conflicting national standards shall be withdrawn at the latest by November 2005.

This document supersedes EN 1514-2:1997.

EN 1514 consists of the following parts, *Flanges and their joints - Dimensions of gaskets for PN-designated flanges*:

- *Part 1: Non-metallic flat gaskets with or without inserts;*
- *Part 2: Spiral wound gaskets for use with steel flanges;*
- *Part 3: Non-metallic PTFE envelope gaskets;*
- *Part 4: Corrugated, flat or grooved metallic and filled metallic gaskets for use with steel flanges;*
- *Part 6: Covered serrated metal gaskets for use with steel flanges;*
- *Part 7: Covered metal jacketed gaskets for use with steel flanges;*
- *Part 8: Polymeric O-Ring gaskets for grooved flanges.*

According to the CEN/CENELEC Internal Regulations, the national standards organizations of the following countries are bound to implement this European Standard: Austria, Belgium, Cyprus, Czech Republic, Denmark, Estonia, Finland, France, Germany, Greece, Hungary, Iceland, Ireland, Italy, Latvia, Lithuania, Luxembourg, Malta, Netherlands, Norway, Poland, Portugal, Slovakia, Slovenia, Spain, Sweden, Switzerland and United Kingdom.

Introduction

This European Standard replaces an earlier one issued in 1997. The reason for the revision is to ensure that the standard reflects the current practice within the German Chemical Industry. The dimension of the various components of the spiral wound gaskets described and their tolerances have been set with the objective of controlling the possibility of protrusion of the inner ring into the bore of the pipeline being sealed. The other features of the standard have been set in order to ensure good functionality of spiral wound gaskets made to this European Standard.

The dimensions of spiral wound gaskets for tongue and groove flanges and spigot and recess flanges to EN 1092-1 are not included in this European Standard. Such gaskets may be available, however, for these types of flanges and the purchaser is advised to consult the manufacturer as to their availability.

1 Scope

This European Standard specifies the dimensions and marking of spiral wound gaskets for use in conjunction with flat face and raised face flanges complying with EN 1092-1 for PN 10, PN 16, PN 25, PN 40, PN 63, PN 100 and PN 160 and up to and including DN 1000.

NOTE 1 Dimensions of other types of gaskets for use with flanges to EN 1092-1, EN 1092-2, EN 1092-3 and EN 1092-4 are given in EN 1514-1, EN 1514-3, EN 1514-4, EN 1514-6, EN 1514-7 and EN 1514-8.

NOTE 2 Annex A lists information that should be supplied by the purchaser when ordering gaskets in circumstances where the choice of the gasket materials appropriate to the service is left to the supplier.

2 Normative references

The following referenced documents are indispensable for the application of this document. For dated references, only the edition cited applies. For undated references, the latest edition of the referenced document (including any amendments) applies.

EN 1333, *Pipework components — Definition and selection of PN*.

EN ISO 6708, *Pipework components — Definition and selection of DN (nominal size) (ISO 6708:1995)*.

3 Terms and definitions

For the purposes of this European Standard, the following terms and definitions apply.

3.1

DN

see EN ISO 6708

3.2

PN

see EN 1333

4 Designations

4.1 Essential Features and Dimensions

4.1.1 General

A major feature of the design of spiral wound gaskets to the requirements of this European Standard is the minimisation of the possibility of the inner ring protruding into the bore of the pipe to which the flange is attached. The fit of the inner ring and sealing element relative to the outer ring has been selected to comply with this objective.

The essential features of a spiral wound gasket in compliance with this specification are given in Figures 1 and 2 and/or are listed below.

Movement of centre of inner ring relative to guide ring	Up to DN 200 a maximum of 0,2 mm
	Above DN 200 a maximum of 0,4 mm
Guide Ring Thickness	3 mm ± 0,25

Sealing element location groove shall be centrally located in the guide ring	Centre $\pm 0,1$ mm
Number of empty wraps on external diameter of the sealing element	3 to 5
Number of empty wraps on the internal diameter of the sealing element	2 to 3
Number of welds on the inner and outer diameters of the sealing element, i.e. on the empty wraps	Minimum of 4
Thickness of the metal of the sealing element	0,2 mm $\pm 0,02$ mm
Width of the profiled metal of the sealing element	4,5 mm $^{+0.3}_0$
Thickness of the filler material shall be as appropriate for the filler type	
Protrusion of the filler above the profiled metal of the sealing element	0,3 $\pm 0,1$ mm
Compression of the sealing element shall not result in contact between the flange and the guide ring, see also 4.1.2	
Graphite ash content	maximum of 2 %
PTFE filler to contain no recycled material and may be either sintered or non-sintered	
Sharp edges on inner ring and guide ring to be removed	
Dimensions to be as given in Table 1	

4.1.2 Maximum Compression

Metal to metal contact between the guide ring and the flange shall not be achieved with the maximum load that can be generated by the flange bolts.

4.1.3 The Use of an Inner Ring

An inner ring shall be used with all gaskets using PTFE as the filler and with all gaskets for pressure groups PN 63, PN 100 and PN 160.

In addition to the above, it is strongly recommended that an inner ring should be used with all gaskets, this should therefore be specified on the order for all gaskets for pressure groups PN 10, PN 25 and PN 40.

4.2 Range of PN Designations

Gaskets shall be designated as suitable for use with one or more of the following PN designations of flanges:

- | | |
|-------|--------|
| PN 10 | PN 63 |
| PN 25 | PN 100 |
| PN 40 | PN 160 |

4.3 Range of DN (nominal sizes)

Gasket nominal sizes shall be designated in accordance with the ranges specified in Table 1.

4.4 Gasket types

Gasket types, as defined in Clause 6 and as illustrated in Figure 3, shall be designated as:

- Type C/I: Sealing element with centring ring and inner ring;
- Type C/O: Sealing element with centring ring.

4.5 Information to be supplied by the purchaser

NOTE Where the purchaser wants the manufacturer to specify the materials of the gasket then the information that should be supplied to the manufacturer with the order is given in Annex A.

5 Gasket designs

Gaskets for which dimensions are specified shall be of one of the designs shown in Figure 1.

The clearance between the sealing element and the centring ring shall be as shown in Figure 2.

NOTE 1 Figure 1 shows a typical design of a metallic spiral wound gasket and, for use with type A or type B flanges.

NOTE 2 Type A and type B flange facings are illustrated in EN 1092-1.

NOTE 3 The profile of the metal winding of the sealing element is at the option of the manufacturer.

NOTE 4 The materials of the gasket may be either specified by the purchaser or, if required by the purchaser, they may be chosen by the manufacturer to suit the operating conditions. In the latter case, the purchaser should define the operating conditions in the enquiry and/or order (see Annex A).

NOTE 5 The attention of the user is drawn to the load necessary to compress spiral wound gaskets and the available load with PN 10 flanges should be verified as adequate prior to using these gaskets.

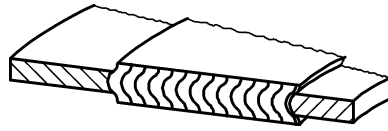

a) Type C/I

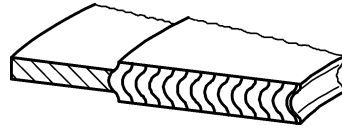

b) Type C/O

Figure 1 — Spiral wound gaskets

6 Gasket types

Gaskets shall be one of the following types:

- a) Type C/I Sealing element with centring ring and inner ring;
- b) Type C/O Sealing element with centring ring.

All gaskets shall have a centring ring. All PN 63, PN 100 and PN 160 gaskets shall have an inner ring. All gaskets containing PTFE filler material shall have an inner ring.

NOTE 1 The use of an inner ring is recommended for all PN designations and the purchaser should specify on the enquiry and/or order if an inner ring is required for PN 10, PN 25 and PN 40 gaskets (see Annex A).

NOTE 2 The selection of gasket type should take into account the fluids, the operating conditions, the properties of the gasket materials, the type and surface finish of the flange facing and the flange bolt loading. It is recommended that selection of gaskets for any particular application is made in consultation with the gasket supplier (see Annex A).

7 Dimensions

The dimensions of spiral wound gaskets for types A and B flange facings shall be as given in Table 1 and overall thickness, including filler, shall be as given in Figure 2.

Dimensions in millimetres

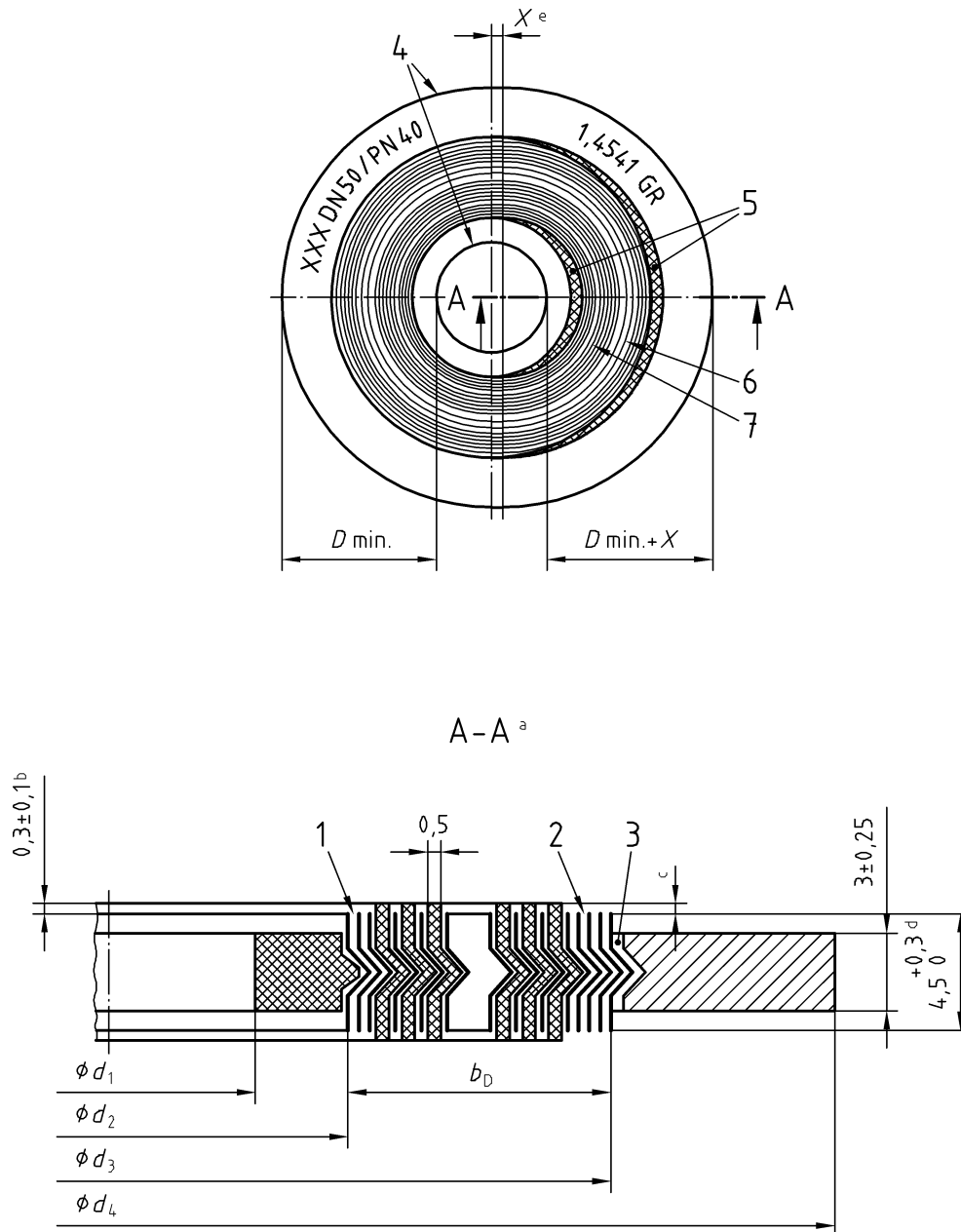
**Key**

- | | |
|--|---|
| <p>a See Table 1 for details</p> <p>b Protrusion minimum of 0,2 mm</p> <p>c Gasket shall not compress such that metal to metal contact between flange and guide rings is achieved</p> <p>d Width (of profiled metal of the sealing element)</p> <p>e Tolerance:
Up to DN 200 max. 0,2 mm, > DN 200 max. 0,4 mm.</p> | <p>1 2 to 3 empty wraps</p> <p>2 3 to 5 empty wraps</p> <p>3 Central groove $\pm 0,1$ mm</p> <p>4 Sharp edges removed</p> <p>5 Minimum of four welding points for each</p> <p>6 Metal thickness $0,2 \text{ mm} \pm 0,02$ mm</p> <p>7 Thickness as appropriate to filler type
Graphite Ash content < 2 %, PTFE filler to contain no re-cycled material and may be either sintered or non-sintered.</p> |
|--|---|

This parameter controls the amount by which the ring might protrude into the pipe bore

Figure 2 — Spiral wound gasket details

Table 1 — Dimensions

DN	Inner diameter of the inner ring d_1	Width of the inner ring $b_{IR \text{ min}}$	Inner diameter of the sealing element $d_2 \text{ min}$	Width of the sealing element $b_D \text{ min}$	Inner diameter of the guide ring $d_3 \text{ min}$	Width of the sealing element $b_D \text{ min}$	Inner diameter of the guide ring $d_3 \text{ min}$	Outside diameter of the guide ring for each pressure class					
								d_4					
								PN 10, PN 25, PN 40	PN 63, PN 100, PN 160	PN 10	PN 25	PN 40	PN 63
10	18	3	24	5	34	5	34	46			56		
15	23	3	29	5	39	5	39	51			61		
20	28	3	34	6	46	—	—	61			—		
25	35	3	41	6	53	6	53	71			82		
32	43	3	49	6	61	—	—	82			—		
40	50	3	56	6	68	6	68	92			103		
50	61	4,5	70	8	86	8	86	107			113	119	
65	77	4,5	86	8	102	10	106	127			137	143	
80	90	4,5	99	8	115	10	119	142			148	154	
100	115	6	127	8	143	10	147	162	168		174	180	
125	140	6	152	10	172	12	176	192	194		210	217	
150	167	6	179	10	199	12	203	217	224		247	257	
200	216	6	228	10	248	12	252	272	284	290	309	324	
250	267	6	279	12	303	14	307	327	340	352	364	391	388
300	318	6	330	12	354	14	358	377	400	417	424	458	458
350	360	8	376	12	400	14	404	437	457	474	486	512	
400	410	6	422	14	450	17	456	488	514	546	543	572	
500	510	6	522	14	550	17	556	593	624	628	657	704	
600	610	6	622	14	650	17	656	695	731	747	764	813	
700	710	6	722	17	756	20	762	810	833	852	879	950	
800	810	10	830	17	864	20	870	917	942	974	988		
900	910	10	930	17	964	20	970	1 017	1 042	1 084	1 108		
1 000	1 010	10	1 030	22	1 074	25	1 080	1 124	1 154	1 194			

With these dimensions the inner ring will not protrude into the bore of the pipe to be sealed

8 Marking

8.1 General

The guide ring shall be marked with the following information:

- a) Manufacturer's name or trade mark;
- b) DN followed by the appropriate number;
- c) PN designation followed by the appropriate number;
- d) The manufacturer's symbols or colour coding as required in 8.2 for the materials of the metal winding, the filler material and centring ring, unless the latter is carbon steel, and inner ring unless it is 304 stainless steel.

EXAMPLE of guide ring marking: AAA/BBB, DN 300, PN 25, XXX

Gaskets shall be identified either individually or on the packaging containing the gasket(s) with the number of this European Standard, i.e. EN 1514-2.

8.2 Colour Coding

Spiral wound gaskets shall be marked with colour codes that identify the metal of the winding strip and the filler material.

A continuous colour around the centring ring edge shall identify the metal of the winding strip.

Intermittent stripes around the edge of the centring ring shall identify the filler material. For gasket sizes below DN 40 there will be a minimum of two stripes spaced approximately 180 degrees apart. For gaskets of DN 40 and above there will be a minimum of four stripes spaced approximately 90 degrees apart.

The colour codes shall conform to those listed in Table 2, for materials not given in Table 2, the colour code shall be agreed between the purchaser and the manufacturer.

Table 2 — Colour coding and abbreviations for spiral-wound gasket materials

Material (Material number)	Abbreviation	Colour code
Metallic materials		
Carbon steel	CRS	Silver
X4CrNi 18-10 (1.4301)	304	Yellow
X2CrNi 19-11 (1.4306)	304 L	No colour ^a
X15CrNiSi 20-12 (1.4828)	309	No colour ^a
X15CrNiSi 25-20 (1.4841)	310	No colour ^a
X5CrNiMo 17-12-2 (1.4401)	316	Green
X2CrNiMo 17-12-2 (1.4404)	316 L	Green
X6CrNiNb 18-10 (1.4550)	347	Blue
X6CrNiTi 18-10 (1.4541)	321	Turquoise
X6Cr 17 (1.4016)	430	No colour ^a
NiCu30Fe (2.4360)	MON	Orange
Ni99.2 (2.4066)	NI	Red
Titanium	TI	Purple
NiCr20CuMo (2.4660)	A-20	Black
NiMo28 (2.4617)	HAST B	Brown
NiMo16Cr15W (2.4819)	HAST C	Beige
NiCr15Fe (2.4816)	INC 600	Gold
NiCr22Mo9Nb (2.4856)	INC 625	Gold
NiCr15Fe7TiAl (2.4669)	INX	No colour ^a
X10NiCrAlTi32-20 (1.4876)	IN 800	White
NiCr21Mo (2.4858)	IN 825	White
Zirconium	ZIRC	No colour ^a
Nonmetallic filler materials		
Chrysotile asbestos	ASB	No stripe
Polytetrafluoroethylene	PTFE	White stripe
Mica-graphite	Manufacturer's designation	Pink stripe
Flexible-graphite	F.G.	Grey stripe
Ceramic	CER	Light Green stripe

^a To prevent a mix-up of gaskets of the same type made from different materials it is recommendable to define a certain colour code between the gasket supplier and the purchaser.

Annex A (informative)

Information to be supplied by the purchaser

Before ordering a gasket it is recommended that the selection of the gasket type should be made in consultation with the gasket supplier. The selection of gasket type should take account of the fluid, the operating conditions, the properties of the gasket materials, the type and surface finish of the flange facing and the flange bolt loading.

The following information should be supplied by the purchaser when ordering gaskets:

- a) reference to this European Standard, i.e. EN 1514-2;
- b) gasket type (see 4.3);
- c) DN (see Table 1) and any requirement for a specific inner ring inside diameter;
- d) PN designation (see Table 1);
- e) whether an inner ring is required (see NOTES 1 and 2 to Clause 6);
- f) expected operating conditions for which the gasket will be used.

Bibliography

- [1] EN 1092-1, *Flanges and their joints — Circular flanges for pipes, valves, fittings and accessories, PN designated — Part 1: Steel flanges.*
- [2] EN 1092-2, *Flanges and their joints — Circular flanges for pipes, valves, fittings and accessories, PN designated — Part 2: Cast iron flanges.*
- [3] EN 1092-3, *Flanges and their joints — Circular flanges for pipes, valves, fittings and accessories, PN designated — Part 3: Copper alloy flanges.*
- [4] EN 1092-4, *Flanges and their joints — Circular flanges for pipes, valves, fittings and accessories, PN designated — Part 4: Aluminium alloy flanges.*
- [5] EN 13555, *Flanges and their joints — Gasket parameters and test procedures relevant to the design rules for gasketed circular flange connections.*

BSI — British Standards Institution

BSI is the independent national body responsible for preparing British Standards. It presents the UK view on standards in Europe and at the international level. It is incorporated by Royal Charter.

Revisions

British Standards are updated by amendment or revision. Users of British Standards should make sure that they possess the latest amendments or editions.

It is the constant aim of BSI to improve the quality of our products and services. We would be grateful if anyone finding an inaccuracy or ambiguity while using this British Standard would inform the Secretary of the technical committee responsible, the identity of which can be found on the inside front cover.
Tel: +44 (0)20 8996 9000. Fax: +44 (0)20 8996 7400.

BSI offers members an individual updating service called PLUS which ensures that subscribers automatically receive the latest editions of standards.

Buying standards

Orders for all BSI, international and foreign standards publications should be addressed to Customer Services. Tel: +44 (0)20 8996 9001.
Fax: +44 (0)20 8996 7001. Email: orders@bsi-global.com. Standards are also available from the BSI website at <http://www.bsi-global.com>.

In response to orders for international standards, it is BSI policy to supply the BSI implementation of those that have been published as British Standards, unless otherwise requested.

Information on standards

BSI provides a wide range of information on national, European and international standards through its Library and its Technical Help to Exporters Service. Various BSI electronic information services are also available which give details on all its products and services. Contact the Information Centre.
Tel: +44 (0)20 8996 7111. Fax: +44 (0)20 8996 7048. Email: info@bsi-global.com.

Subscribing members of BSI are kept up to date with standards developments and receive substantial discounts on the purchase price of standards. For details of these and other benefits contact Membership Administration.
Tel: +44 (0)20 8996 7002. Fax: +44 (0)20 8996 7001.
Email: membership@bsi-global.com.

Information regarding online access to British Standards via British Standards Online can be found at <http://www.bsi-global.com/bsonline>.

Further information about BSI is available on the BSI website at <http://www.bsi-global.com>.

Copyright

Copyright subsists in all BSI publications. BSI also holds the copyright, in the UK, of the publications of the international standardization bodies. Except as permitted under the Copyright, Designs and Patents Act 1988 no extract may be reproduced, stored in a retrieval system or transmitted in any form or by any means – electronic, photocopying, recording or otherwise – without prior written permission from BSI.

This does not preclude the free use, in the course of implementing the standard, of necessary details such as symbols, and size, type or grade designations. If these details are to be used for any other purpose than implementation then the prior written permission of BSI must be obtained.

Details and advice can be obtained from the Copyright & Licensing Manager.
Tel: +44 (0)20 8996 7070. Fax: +44 (0)20 8996 7553.
Email: copyright@bsi-global.com.