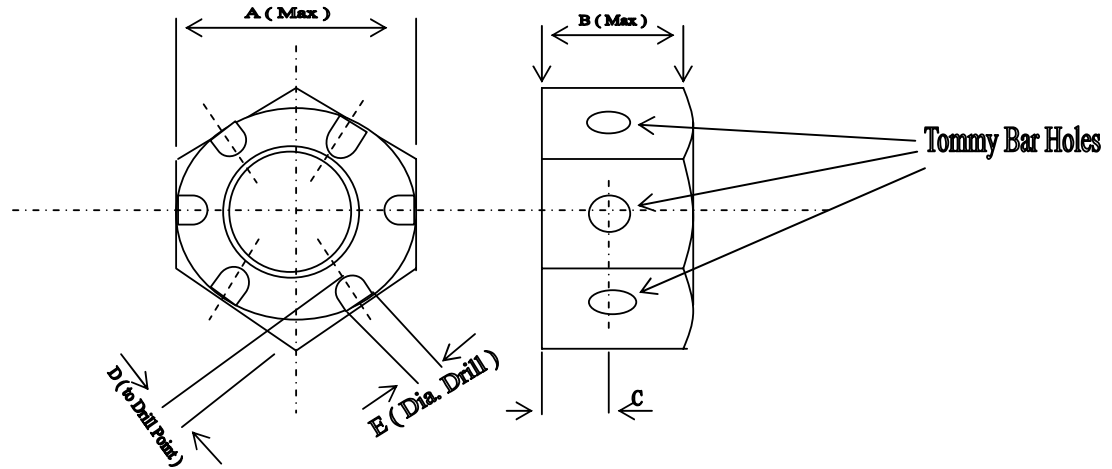

**Figure 1 - Dimensions Of Tommy Bar Holes**



Nominal Thread Diameter	A (Inches)	B (Inches)	C (mm)	D (mm)	E (mm)	Tommy Bar Size (mm)
3/4"	1.250	0.758	9	5	6.2	6
7/8"	1.437	0.885	9	5	6.2	6
1"	1.625	1.012	9	6	6.2	6
1 1/8"	1.812	1.139	9	6	6.2	6
1 1/4"	2.000	1.251	12	8	8.2	8
1 3/8"	2.187	1.378	12	8	8.2	8
1 1/2"	2.375	1.505	15	9	10.2	10
1 5/8"	2.562	1.632	15	9	10.2	10
1 3/4"	2.750	1.759	15	10	10.2	10
1 7/8"	2.937	1.886	15	10	10.2	10
2"	3.125	2.013	18	12	12.4	12
2 1/4"	3.500	2.251	18	12	12.4	12
2 1/2"	3.875	2.505	21	14	14.4	14
2 3/4"	4.250	2.759	21	14	14.4	14
3"	4.625	3.013	24	16	16.4	16
3 1/4"	5.000	3.251	24	17	16.4	16
3 1/2"	5.375	3.506	24	18	16.4	16
3 3/4"	5.750	3.758	24	18	16.4	16
4"	6.125	4.013	24	18	16.4	16

Basic significant dimension conform to BS4882 and ANSI B 18.2.2 Heavy Series (UNC threads up to 1" dia. UN-ETPI on 1 1/4" dia. And above). They are normally supplied in Grade 2H material, other grades are available. Metric nut and nuts with special dimensions can be supplied to meet customer's specific requirements.