

**ASME B16.20-2007**  
(Revision of ASME B16.20-1998)

# **Metallic Gaskets for Pipe Flanges**

**Ring-Joint, Spiral-Wound,  
and Jacketed**

**AN AMERICAN NATIONAL STANDARD**



**The American Society of  
Mechanical Engineers**



**ASME B16.20-2007**  
**(Revision of ASME B16.20-1998)**

# **Metallic Gaskets for Pipe Flanges**

**Ring-Joint, Spiral-Wound, and  
Jacketed**

**AN AMERICAN NATIONAL STANDARD**



Date of Issuance: May 19, 2008

The next edition of this Standard is scheduled for publication in 2013. There will be no addenda issued to this edition.

ASME issues written replies to inquiries concerning interpretations of technical aspects of this Standard. Interpretations are published on the ASME Web site under the Committee Pages at <http://cstools.asme.org> as they are issued.

ASME is the registered trademark of The American Society of Mechanical Engineers.

This code or standard was developed under procedures accredited as meeting the criteria for American National Standards. The Standards Committee that approved the code or standard was balanced to assure that individuals from competent and concerned interests have had an opportunity to participate. The proposed code or standard was made available for public review and comment that provides an opportunity for additional public input from industry, academia, regulatory agencies, and the public-at-large.

ASME does not “approve,” “rate,” or “endorse” any item, construction, proprietary device, or activity.

ASME does not take any position with respect to the validity of any patent rights asserted in connection with any items mentioned in this document, and does not undertake to insure anyone utilizing a standard against liability for infringement of any applicable letters patent, nor assume any such liability. Users of a code or standard are expressly advised that determination of the validity of any such patent rights, and the risk of infringement of such rights, is entirely their own responsibility.

Participation by federal agency representative(s) or person(s) affiliated with industry is not to be interpreted as government or industry endorsement of this code or standard.

ASME accepts responsibility for only those interpretations of this document issued in accordance with the established ASME procedures and policies, which precludes the issuance of interpretations by individuals.

No part of this document may be reproduced in any form,  
in an electronic retrieval system or otherwise,  
without the prior written permission of the publisher.

The American Society of Mechanical Engineers  
Three Park Avenue, New York, NY 10016-5990

Copyright © 2008 by  
THE AMERICAN SOCIETY OF MECHANICAL ENGINEERS  
All rights reserved  
Printed in U.S.A.

# CONTENTS

Foreword .....	iv
Committee Roster .....	v
Correspondence With the B16 Committee .....	vi
Important Information Concerning Use of Asbestos or Alternative Materials .....	vii
<b>1 Scope</b> .....	1
<b>2 Ring-Joint Gaskets</b> .....	1
<b>3 Spiral-Wound Gaskets</b> .....	2
<b>4 Jacketed Gaskets</b> .....	3
<b>Tables</b>	
1 Maximum Hardness for Ring Gaskets .....	1
2 Ring Gasket Markings .....	2
3 Type R Ring Gasket Dimensions and Tolerances .....	4
4 Pipe Sizes for Type R Ring Gaskets Suitable for Referenced Standards .....	7
5 Type RX Ring Gasket Dimensions and Tolerances .....	9
6 Pipe Sizes for Type RX Ring Gaskets Suitable for Referenced Standards .....	11
7 Type BX Ring Gasket Dimensions and Tolerances .....	12
8 Pipe Sizes for Type BX Ring Gaskets Suitable for Referenced Standards .....	13
9 Dimensions for Spiral-Wound Gaskets Used With ASME B16.5 Flanges .....	14
10 Dimensions for Spiral-Wound Gaskets Used With ASME B16.47 Series A Flanges ....	16
11 Dimensions for Spiral-Wound Gaskets Used With ASME B16.47 Series B Flanges ....	18
12 Inner-Ring Inside Diameters for Spiral-Wound Gaskets for Use With ASME B16.5 Flanges .....	20
13 Inner-Ring Inside Diameters for Spiral-Wound Gaskets Used Between ASME B16.47 Series A Flanges .....	21
14 Inner-Ring Inside Diameters for Spiral-Wound Gaskets Used Between ASME B16.47 Series B Flanges .....	22
15 Minimum Pipe Wall Thickness Suitable for Use of Spiral-Wound Gaskets With Inner Rings for ASME B16.5 Flanges .....	23
16 Maximum Bore of ASME B16.5 Flanges for Use With Spiral-Wound Gaskets .....	24
17 Maximum Bore of ASME B16.47 Series A Flanges for Use With Spiral-Wound Gaskets .....	25
18 Maximum Bore of ASME B16.47 Series B Flanges for Use With Spiral-Wound Gaskets .....	26
19 Color Coding and Abbreviations for Spiral-Wound Gasket Materials .....	27
20 Example Markings for Spiral-Wound Gaskets .....	28
21 Jacketed Gasket Dimensions for ASME B16.5 Flanges .....	29
22 Jacketed Gasket Dimensions for ASME B16.47 Series A Flanges .....	30
23 Jacketed Gasket Dimensions for ASME B16.47 Series B Flanges .....	31
24 Abbreviations for Identifying Materials for Jacketed Gaskets .....	32
25 Example Markings for Jacketed Gaskets .....	32
<b>Mandatory Appendices</b>	
I Dimensions of Gaskets in U.S. Customary Units .....	33
II References .....	54
<b>Nonmandatory Appendix</b>	
A Quality System Program .....	55

# FOREWORD

Ring-joint gaskets and grooves probably originated in the boiler field, where they were used in various forms for manhole covers, autoclaves, and other closures; however, it was in the oil industry (both in the production and refining of oil) that they received the greatest recognition and were developed into their present form. Their use expanded steadily as temperatures and pressures were increased in steam plants. Tests examining their application in flanges and valves were conducted as early as 1928.

In June 1936, the American Petroleum Institute (API) issued Tentative Standard 5-G-3 on Ring-Joints for Steel Flanges and Flange Unions for use with API Tubular Goods. This standard was known as API Specification 6B, Ring-Joint Flanges. Following the acceptance of ring-joints for flanges and valves by API and the issuance of their standard, ASA B16e on Steel Pipe Flanges and Flanged Fittings was revised to include them, and the 1939 edition included standard dimensions for a full line of ring-joint flanges based on the API standard. Development work continued and API formulated Standard 6E, Specification for Wellhead Equipment, which included ring-joints not covered in ASA B16e-1939.

In 1949, the American Standards Association (ASA), Sectional Committee B16, Subcommittee 3, Steel Flanges and Flanged Fittings, assembled the available information on ring-joint gaskets into a single standard. ASA approval was granted on April 30, 1952, with the designation ASA B16.20-1952.

An updated version was submitted and ASA approval was granted on April 4, 1955, with the designation ASA B16.20-1955. Ring gaskets for Class 900 (900 lb at that time) in sizes NPS 26 through 36 were added and ASA approval was granted on April 2, 1956. The standard was reviewed in 1962 and approval was granted by the ASA on April 25, 1963.

The standard was again reviewed and approval was granted by the American National Standards Institute (ANSI) on April 25, 1973, with the designation of an American National Standard.

API requested that ASME convert their gasket standard, API 601, into an ASME American National Standard. As a result of that request, the standard was expanded to include requirements for spiral-wound and jacketed gaskets that were formerly listed in API 601, 7th edition, 1988. Also, ring-joint groove dimensions were not included, because they were included in ASME/ANSI B16.5-1988, titled Pipe Flanges and Flanged Fittings, and ASME B16.47-1990, titled Large Diameter Steel Flanges.

The 1993 edition was approved by the B16 Standards Committee and, following approval by ASME, approval by ANSI was given on January 22, 1993, with the designation ASME B16.20-1993.

In the 1998 edition of ASME B16.20, reference standards were updated, a quality system program annex was added, inner ring inside diameters for spiral-wound gaskets were revised, and several editorial revisions were made. Following approval by ASME B16 Subcommittee G and the B16 Main Committee, ANSI approved this American National Standard on November 20, 1998.

In 2007, the standard adopted metric dimensions as an independent standard to the U.S. Customary units; Mandatory Appendix I has been added to cover dimensional tables in U.S. Customary units. Following approval by B16 Subcommittee G, the Standards Committee, and ASME, ANSI approved this American National Standard on October 19, 2007.

# ASME B16 COMMITTEE

## Standardization of Valves, Flanges, Fittings, and Gaskets

(The following is the roster of the Committee at the time of approval of this Standard.)

### STANDARDS COMMITTEE OFFICERS

**H. R. Sonderegger**, *Chair*

**M. L. Nayyar**, *Vice Chair*

**U. D'Urso**, *Secretary*

### STANDARDS COMMITTEE PERSONNEL

**R. W. Barnes**, ANRIC Enterprises, Inc.  
**W. B. Bedesem**, ExxonMobil Research & Engineering Co.  
**M. Clark**, NIBCO, Inc.  
**U. D'Urso**, The American Society of Mechanical Engineers  
**C. E. Floren**, Mueller Co.  
**D. R. Frikken**, Becht Engineering Co.  
**G. G. Grills**, U.S. Coast Guard  
**A. Hamilton**, American Bureau of Shipping  
**M. L. Henderson**, Forgital USA  
**G. A. Jolly**, Vogt Valves/Flowserve  
**M. Katcher**, Haynes International  
**W. G. Knecht**, Consultant  
**W. N. McLean**, Newco Valves  
**T. A. McMahon**, Fisher Controls International, Inc.  
**M. L. Nayyar**, Bechtel Power Corp.  
**J. D. Page**, U.S. Nuclear Regulatory Commission  
**R. A. Schmidt**, Trinity-Ladish  
**H. R. Sonderegger**, Anvil International, Inc.  
**W. M. Stephan**, Flexitallic LP  
**T. F. Stroud**, Ductile Iron Pipe Research Association  
**R. E. White**, Richard E. White & Associates PC  
**D. A. Williams**, Southern Co. Services

### SUBCOMMITTEE G — GASKETS FOR FLANGED JOINTS

**W. M. Stephan**, *Chair*, Flexitallic LP  
**C. B. Gillis**, *Vice Chair*, Teadit North America  
**T. Lazar**, *Secretary*, The American Society of Mechanical Engineers  
**K. A. Benton**, Consultant  
**D. R. Frikken**, Becht Engineering Co.  
**W. E. Holden**, Solutia, Inc.  
**K. Kolb**, Lamons Gasket Co.  
**E. J. Lain**, Flint Hills Resources  
**D. H. Monroe**, Consultant  
**R. T. Mueller**, Consultant  
**P. S. Petrunich**, Fluid Sealing Association  
**M. Pollock**, Graftech International  
**D. F. Reid**, Virginia Sealing Products  
**J. T. White**, Puget Sound Naval Shipyard

## CORRESPONDENCE WITH THE B16 COMMITTEE

**General.** ASME Standards are developed and maintained with the intent to represent the consensus of concerned interests. As such, users of this Standard may interact with the Committee by requesting interpretations, proposing revisions, and attending Committee meetings. Correspondence should be addressed to:

Secretary, B16 Standards Committee  
The American Society of Mechanical Engineers  
Three Park Avenue  
New York, NY 10016-5990

As an alternative, inquiries may be submitted via email to: [SecretaryB16@asme.org](mailto:SecretaryB16@asme.org).

**Proposing Revisions.** Revisions are made periodically to the Standard to incorporate changes that appear necessary or desirable, as demonstrated by the experience gained from the application of the Standard. Approved revisions will be published periodically.

The Committee welcomes proposals for revisions to this Standard. Such proposals should be as specific as possible, citing the paragraph number(s), the proposed wording, and a detailed description of the reasons for the proposal, including any pertinent documentation.

**Interpretations.** Upon request, the B16 Committee will render an interpretation of any requirement of the Standard. Interpretations can only be rendered in response to a written request sent to the Secretary of the B16 Standards Committee.

The request for interpretation should be clear and unambiguous. It is further recommended that the inquirer submit his/her request in the following format:

Subject:	Cite the applicable paragraph number(s) and the topic of the inquiry.
Edition:	Cite the applicable edition of the Standard for which the interpretation is being requested.
Question:	Phrase the question as a request for an interpretation of a specific requirement suitable for general understanding and use, not as a request for an approval of a proprietary design or situation. The inquirer may also include any plans or drawings that are necessary to explain the question; however, they should not contain proprietary names or information.

Requests that are not in this format will be rewritten in this format by the Committee prior to being answered, which may inadvertently change the intent of the original request.

ASME procedures provide for reconsideration of any interpretation when or if additional information that might affect an interpretation is available. Further, persons aggrieved by an interpretation may appeal to the cognizant ASME Committee or Subcommittee. ASME does not "approve," "certify," "rate," or "endorse" any item, construction, proprietary device, or activity.

**Attending Committee Meetings.** The B16 Standards Committee regularly holds meetings, which are open to the public. Persons wishing to attend any meeting should contact the Secretary of the B16 Standards Committee.

## **IMPORTANT INFORMATION CONCERNING USE OF ASBESTOS OR ALTERNATIVE MATERIALS**

Asbestos is referenced for use as a filler material in metallic gaskets. It has served as a universal sealing material, compatible with most fluid services. It has been of extreme usefulness in minimizing fire hazards.

Certain serious adverse health effects are associated with asbestos, among them the serious and often fatal diseases of lung cancer, asbestosis, and mesothelioma (a cancer of the chest and abdominal linings). The degree of exposure to asbestos varies with the product and the work practices involved.

Consult the most recent edition of the Occupational Safety and Health Administration, U.S. Department of Labor, Occupational Safety and Health Standard for Asbestos, Tremolite, Anthophyllite, and Actinolite, 29 Code of Federal Regulations Section 1910.1001; the U.S. Environmental Protection Agency National Emission Standard for Asbestos, 40 Code of Federal Regulations Sections 61.140 through 61.156; and the proposed rule by the U.S. Environmental Protection Agency proposing labeling requirements and phased banning of asbestos products, published at 51 Federal Register 3738-3759 (January 29, 1986).

There are currently in use and under development a number of substitute materials to replace asbestos in certain applications. Manufacturers and users are encouraged to develop and use effective substitute materials that can meet the specifications for, and operating requirements of, the equipment to which they would apply.

Information concerning safety and health risks and proper precautions with respect to particular materials and conditions should be obtained from one's employer, the manufacturer or supplier of that material, or the Material Safety Data Sheet.



INTENTIONALLY LEFT BLANK

# METALLIC GASKETS FOR PIPE FLANGES

## Ring-Joint, Spiral-Wound, and Jacketed

### 1 SCOPE

#### 1.1 General

This Standard covers materials, dimensions, tolerances, and markings for metal ring-joint gaskets, spiral-wound metal gaskets, and metal-jacketed gaskets. These gaskets are dimensionally suitable for use with flanges described in reference flange standards ASME B16.5, ASME B16.47, API Specification 6A, and ISO 10423. This Standard covers spiral-wound metal gaskets and metal-jacketed gaskets for use with raised-face and flat-face flanges.

#### 1.2 Quality Systems

Requirements relating to the product manufacturers' quality system programs are described in Nonmandatory Appendix A.

#### 1.3 References

Standards and specifications adopted by reference in this Standard are shown in Mandatory Appendix II, which is part of this Standard.

#### 1.4 Relevant Units

This Standard states values in both metric and U.S. Customary units. These systems of units are to be regarded separately as standard.

Within the text, the U.S. Customary units are shown in parentheses or in separate tables. The values stated in each system are not exact equivalents; therefore, it is required that each system of units be used independently of the other. Combining values from the two systems constitutes nonconformance with the Standard.

## 2 RING-JOINT GASKETS

### 2.1 Types

Ring-joint gaskets shall be either octagonal or oval in cross section.

### 2.2 Size

Ring-joint gaskets shall be identified by an R, RX, or BX number that relates to flange size (NPS), pressure class, and the appropriate flange standards (ASME B16.5, ASME B16.47, API Specification 6A, or ISO 10423).

**Table 1 Maximum Hardness for Ring Gaskets**

Ring Gasket Material	Maximum Hardness	
	Brinell	Rockwell "B" Scale
Soft iron [Note (1)]	90	56
Low-carbon steel	120	68
4–6 chrome $\frac{1}{2}$ Mo	130	72
Type 410	170	86
Type 304	160	83
Type 316	160	83
Type 347	160	83

NOTE:

(1) May be low-carbon steel, not to exceed maximum hardness of 90 Brinell – 56 Rockwell "B."

### 2.3 Materials

**2.3.1 General.** Ring-joint gasket materials, some of which are listed in Table 1, shall be selected by the user based on suitability for the service conditions.

It is recommended that ring-joint gaskets be of a lesser hardness than that of the mating flanges.

**2.3.2 Hardness.** Ring-joint gaskets of materials listed in Table 1 shall have a hardness equal to or less than that shown in Table 1.

### 2.4 Marking

The outer surface of each gasket shall carry the manufacturer's name or identification trademark and gasket number prefixed by the letters R, RX, or BX, followed by the gasket material identification. Materials shall be identified as shown in Table 2. The gasket shall also be marked with an ASME B16.20 designation. The marking shall be applied so as not to harmfully distort the gasket or affect the integrity of the seal.

### 2.5 Dimensions and Tolerances

Dimensions and tolerances for ring-joint gaskets shall be as shown in Tables 3 through 8 (Tables I-1, I-2, and I-3 of Mandatory Appendix I).

### 2.6 Surface Finish

Types R and RX gaskets shall have a surface finish not rougher than 1.6  $\mu\text{m}$  (63  $\mu\text{in.}$ ) roughness. Type BX

**Table 2 Ring Gasket Markings**

Ring Gasket Material	Identification	Marking Example [Note (1)]
Soft iron [Note (2)]	D	R51D
Low-carbon steel	S	R51S
4–6 chrome $\frac{1}{2}$ Mo	F5 [Note (3)]	R51F5
Type 410	S 410	R51S410
Type 304	S 304	R51S304
Type 316	S 316	R51S316
Type 347	S 347	R51S347

## NOTES:

- (1) This number shall be preceded by the manufacturer's name or identification trademark.
- (2) May be low-carbon steel, not to exceed maximum hardness of 90 Brinell – 56 Rockwell "B."
- (3) F5 identification designates ASTM Specification A 182-72 chemical composition requirements only.

gaskets shall have a surface finish not rougher than  $0.8 \mu\text{m}$  ( $32 \mu\text{in.}$ ) roughness. Surface finish shall pertain to the gasket-sealing surface.

### 2.7 Identification Number

Dimensional reference identification numbers are assigned to ring-joint gaskets and are shown in Tables 3 through 8 (Tables I-1, I-2, and I-3 of Mandatory Appendix I).

## 3 SPIRAL-WOUND GASKETS

### 3.1 Size and Class

Spiral-wound gaskets, including centering ring and inner ring (paras. 3.2.4 and 3.2.5), are identified by flange size (NPS), pressure class, and the appropriate flange standard (ASME B16.5 or ASME B16.47).

### 3.2 Dimensions and Tolerances

**3.2.1 General.** Dimensions and tolerances for spiral-wound gaskets, centering rings, and inner rings shall be in accordance with Tables 9 through 14 (Tables I-4 through I-9 of Mandatory Appendix I) and as specified in this section.

**3.2.2 Construction.** Spiral-wound gaskets shall be constructed as alternate plies (circular layers counted as revolutions) of preformed metal windings and pliant fillers that are spirally wound. For the finished gasket, the filler shall be essentially flush with, but not below, the metal winding on both contact faces of the gasket. The metal strip in the winding shall be  $0.15 \text{ mm}$  ( $0.006 \text{ in.}$ ) to  $0.23 \text{ mm}$  ( $0.009 \text{ in.}$ ) thick. The filler material thickness shall be determined by the manufacturer.

**3.2.3 Metal Joining.** The inner windings shall have a minimum of three plies of preformed metal strip without filler. The initial two plies shall have spot welds spaced

around the inner circumference. The minimum number of welds shall be three. The maximum distance between welds shall be  $76 \text{ mm}$  ( $3.0 \text{ in.}$ ). The outer windings, which shall have a minimum of three plies of preformed metal without filler, shall be spot-welded circumferentially with a minimum of three welds, the last of which shall be the terminal weld.

The distance of the first weld from the terminal weld shall be no greater than  $38 \text{ mm}$  ( $1.5 \text{ in.}$ ). Up to four additional loose preformed metal windings beyond the terminal weld may be used to retain the gasket into the centering ring.

**3.2.4 Centering Ring.** All spiral-wound gaskets shall be furnished assembled into a centering ring. The centering ring thickness shall be from  $2.97 \text{ mm}$  ( $0.117 \text{ in.}$ ) to  $3.33 \text{ mm}$  ( $0.131 \text{ in.}$ ) and suitably grooved on the inside diameter so as to retain the gasket.

**3.2.5 Inner Ring.** Inward buckling of spiral-wound gaskets has been identified as a potential problem. Inner rings shall be furnished with all spiral-wound gaskets having PTFE (polytetrafluoroethylene) filler material. Inner rings for flexible graphite-filled spiral-wound gaskets shall be furnished unless the purchaser specifies otherwise.

For all filler materials, inner rings shall be furnished in spiral-wound gaskets for

- (a) NPS 24 and larger in Class 900
- (b) NPS 12 and larger in Class 1500
- (c) NPS 4 and larger in Class 2500

Inner rings are required for these gaskets due to high available bolt loads, which may result in outer ring damage.

The inner ring thickness shall be from  $2.97 \text{ mm}$  to  $3.33 \text{ mm}$  ( $0.117 \text{ in.}$  to  $0.131 \text{ in.}$ ).

Tables 12 through 14 (Tables I-7 through I-9 of Mandatory Appendix I) show inner ring inside diameters that may extend a maximum of  $1.5 \text{ mm}$  ( $0.06 \text{ in.}$ ) into the flange bore under the worst combination of flange bore, eccentric installation, and tolerance.

Gaskets with inner rings should be used only with socket welding, lapped, welding neck, and integral flanges. Reference Table 15 for minimum pipe wall thickness for use with gaskets with inner rings. Reference Tables 16, 17, and 18 (Tables I-10 and I-11 of Mandatory Appendix I) for maximum allowable bore for use with gaskets without inner rings.

**3.2.6 Gasket Compression.** Spiral-wound gaskets NPS  $\frac{1}{2}$ , NPS  $\frac{3}{4}$ , and NPS 1 in Classes 150, 300, and 600 shall be designed so that a uniform bolt stress of  $172 \text{ MPa}$  ( $25,000 \text{ psi}$ ), based on the nominal bolt root diameter, will compress the gasket to a thickness of  $3.30 \text{ mm} \pm 0.13 \text{ mm}$  ( $0.130 \text{ in.} \pm 0.005 \text{ in.}$ ). All other gasket sizes and classes shall be designed so that a uniform bolt stress of  $207 \text{ MPa}$  ( $30,000 \text{ psi}$ ) will compress the gasket to a thickness of  $3.30 \text{ mm} \pm 0.13 \text{ mm}$  ( $0.130 \text{ in.} \pm 0.005 \text{ in.}$ ).

### 3.3 Materials

Metal windings and filler materials shall be in accordance with Table 19. The inner ring material should match the winding material unless the purchaser specifies otherwise. The centering ring may be carbon steel that is painted, metal plated, or otherwise coated to inhibit atmospheric corrosion.

### 3.4 Marking

**3.4.1 General.** The centering ring of each spiral-wound gasket shall be permanently marked. The lettering height shall be a minimum of 2.5 mm (0.1 in.). The following information shall be included with the centering ring markings:

- (a) manufacturer's name or trademark.
- (b) flange size (NPS).
- (c) pressure class.
- (d) winding metal abbreviation (see Table 19), except that the abbreviation may be omitted when 304 stainless steel is used.
- (e) filler material abbreviation (see Table 19).
- (f) centering and inner ring metal abbreviation (see Table 19), except that the abbreviation may be omitted when carbon steel is used for the outer ring and 304 stainless steel is used for the inner ring.
- (g) flange identification. Gaskets intended for ASME B16.47 flanges shall be marked B16.47 A or B16.47 B, as applicable. Gaskets intended for ASME B16.5 flanges need not be so marked. Illustrative marking examples are shown in Table 20.
- (h) ASME B16.20 designation.

**3.4.2 Pressure Class.** Gaskets suitable for more than one pressure class shall be marked with all applicable classes, as shown in Table 20.

**3.4.3 Color Coding.** Spiral-wound gaskets shall be marked with a color code that identifies the windings and filler materials. A continuous color around the outer edge of the centering ring shall identify the winding metal. The color identifying the filler material for NPS 1½ and larger shall have four intermittent stripes spaced approximately 90 deg apart on the outer edge of the centering ring. Smaller size gaskets shall have a minimum of two stripes 180 deg apart. The colors shall conform to those listed in Table 19.

## 4 JACKETED GASKETS

### 4.1 Size and Pressure Class

Jacketed gaskets are identified by flange size (NPS), pressure class, and the appropriate flange standard (ASME B16.5 or ASME B16.47).

### 4.2 Design

**4.2.1 General.** Jacketed gaskets shall be made with a filler material enclosed in a metal jacket.

**4.2.2 Jacket Thickness.** The jacket metal thickness shall be a minimum of 0.38 mm (0.015 in.).

**4.2.3 Filler Thickness.** The filler thickness shall be a minimum of 1.5 mm (0.06 in.).

**4.2.4 Miscellaneous.** Other design details, including the density of the filler, shall be the gasket manufacturer's responsibility.

### 4.3 Dimensions and Tolerances

Gasket dimensions and tolerances shall be in accordance with Tables 21, 22, or 23 (Tables I-12, I-13, or I-14 of Mandatory Appendix I).

### 4.4 Materials

Metal jacket and filler material shall be selected from Table 24. For jacketed gasket limitations related to ASME B16.5 applications, see Annex C of ASME B16.5.

### 4.5 Marking

**4.5.1 Applied Marking.** Jacketed gaskets shall be marked with waterproof ink or equivalent. Where gasket size does not permit such markings, a separate attached marking tag may be used. The lettering height shall be a minimum of 5 mm (0.2 in.). The following information shall be included with the markings:

- (a) manufacturer's name or trademark.
- (b) flange size (NPS).
- (c) pressure class.
- (d) jacketed material abbreviation (see Table 24), except that the abbreviation may be omitted when soft carbon steel is used.
- (e) filler material abbreviation (see Table 24).
- (f) flange identification. Gaskets intended for ASME B16.47 flanges shall be marked B16.47 A or B16.47 B, as applicable. Gaskets intended for ASME B16.5 flanges need not be so marked. Illustrative marking examples are shown in Table 25.
- (g) ASME B16.20 designation.

**4.5.2 Pressure Class.** Gaskets suitable for more than one pressure class shall be marked with all applicable classes.

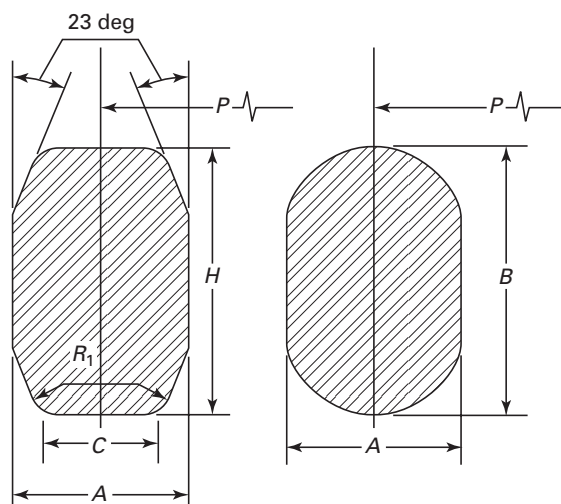
**Table 3 Type R Ring Gasket Dimensions and Tolerances**

Ring Number	Average Pitch Diameter of Ring, $P$	Width of Ring, $A$	Height of Ring		Width of Flat on Octagonal Ring, $C$	Radius in Octagonal Ring, $R_1$
			Oval, $B$	Octagonal, $H$		
R-11	34.14	6.35	11.2	9.7	4.32	1.5
R-12	39.70	7.95	14.2	12.7	5.23	1.5
R-13	42.88	7.95	14.2	12.7	5.23	1.5
R-14	44.45	7.95	14.2	12.7	5.23	1.5
R-15	47.63	7.95	14.2	12.7	5.23	1.5
R-16	50.80	7.95	14.2	12.7	5.23	1.5
R-17	57.15	7.95	14.2	12.7	5.23	1.5
R-18	60.33	7.95	14.2	12.7	5.23	1.5
R-19	65.10	7.95	14.2	12.7	5.23	1.5
R-20	68.28	7.95	14.2	12.7	5.23	1.5
R-21	72.24	11.13	17.5	16.0	7.75	1.5
R-22	82.55	7.95	14.2	12.7	5.23	1.5
R-23	82.55	11.13	17.5	16.0	7.75	1.5
R-24	95.25	11.13	17.5	16.0	7.75	1.5
R-25	101.60	7.95	14.2	12.7	5.23	1.5
R-26	101.60	11.13	17.5	16.0	7.75	1.5
R-27	107.95	11.13	17.5	16.0	7.75	1.5
R-28	111.13	12.70	19.1	17.5	8.66	1.5
R-29	114.30	7.95	14.2	12.7	5.23	1.5
R-30	117.48	11.13	17.5	16.0	7.75	1.5
R-31	123.83	11.13	17.5	16.0	7.75	1.5
R-32	127.00	12.70	19.1	17.5	8.66	1.5
R-33	131.78	7.95	14.2	12.7	5.23	1.5
R-34	131.78	11.13	17.5	16.0	7.75	1.5
R-35	136.53	11.13	17.5	16.0	7.75	1.5
R-36	149.23	7.95	14.2	12.7	5.23	1.5
R-37	149.23	11.13	17.5	16.0	7.75	1.5
R-38	157.18	15.88	22.4	20.6	10.49	1.5
R-39	161.93	11.13	17.5	16.0	7.75	1.5
R-40	171.45	7.95	14.2	12.7	5.23	1.5

**Table 3 Type R Ring Gasket Dimensions and Tolerances (Cont'd)**

Ring Number	Average Pitch Diameter of Ring, <i>P</i>	Width of Ring, <i>A</i>	Height of Ring		Width of Flat on Octagonal Ring, <i>C</i>	Radius in Octagonal Ring, <i>R</i> <sub>1</sub>
			Oval, <i>B</i>	Octagonal, <i>H</i>		
R-41	180.98	11.13	17.5	16.0	7.75	1.5
R-42	190.50	19.05	25.4	23.9	12.32	1.5
R-43	193.68	7.95	14.2	12.7	5.23	1.5
R-44	193.68	11.13	17.5	16.0	7.75	1.5
R-45	211.15	11.13	17.5	16.0	7.75	1.5
R-46	211.15	12.70	19.1	17.5	8.66	1.5
R-47	228.60	19.05	25.4	23.9	12.32	1.5
R-48	247.65	7.95	14.2	12.7	5.23	1.5
R-49	269.88	11.13	17.5	16.0	7.75	1.5
R-50	269.88	15.88	22.4	20.6	10.49	1.5
R-51	279.40	22.23	28.7	26.9	14.81	1.5
R-52	304.80	7.95	14.2	12.7	5.23	1.5
R-53	323.85	11.13	17.5	16.0	7.75	1.5
R-54	323.85	15.88	22.4	20.6	10.49	1.5
R-55	342.90	28.58	36.6	35.1	19.81	2.3
R-56	381.00	7.95	14.2	12.7	5.23	1.5
R-57	381.00	11.13	17.5	16.0	7.75	1.5
R-58	381.00	22.23	28.7	26.9	14.81	1.5
R-59	396.88	7.95	14.2	12.7	5.23	1.5
R-60	406.40	31.75	39.6	38.1	22.33	2.3
R-61	419.10	11.13	17.5	16.0	7.75	1.5
R-62	419.10	15.88	22.4	20.6	10.49	1.5
R-63	419.10	25.40	33.3	31.8	17.30	2.3
R-64	454.03	7.95	14.2	12.7	5.23	1.5
R-65	469.90	11.13	17.5	16.0	7.75	1.5
R-66	469.90	15.88	22.4	20.6	10.49	1.5
R-67	469.90	28.58	36.6	35.1	19.81	2.3
R-68	517.53	7.95	14.2	12.7	5.23	1.5
R-69	533.40	11.13	17.5	16.0	7.75	1.5
R-70	533.40	19.05	25.4	23.9	12.32	1.5
R-71	533.40	28.58	36.6	35.1	19.81	2.3
R-72	558.80	7.95	14.2	12.7	5.23	1.5
R-73	584.20	12.70	19.1	17.5	8.66	1.5
R-74	584.20	19.05	25.4	23.9	12.32	1.5
R-75	584.20	31.75	39.6	38.1	22.33	2.3
R-76	673.10	7.95	14.2	12.7	5.23	1.5
R-77	692.15	15.88	22.4	20.6	10.49	1.5
R-78	692.15	25.40	33.3	31.8	17.30	2.3
R-79	692.15	34.93	44.5	41.4	24.82	2.3
R-80	615.95	7.95	...	12.7	5.23	1.5
R-81	635.00	14.30	...	19.1	9.58	1.5
R-82	57.15	11.13	...	16.0	7.75	1.5
R-84	63.50	11.13	...	16.0	7.75	1.5
R-85	79.38	12.70	...	17.5	8.66	1.5
R-86	90.50	15.88	...	20.6	10.49	1.5
R-87	100.03	15.88	...	20.6	10.49	1.5
R-88	123.83	19.05	...	23.9	12.32	1.5
R-89	114.30	19.05	...	23.9	12.32	1.5
R-90	155.58	22.23	...	26.9	14.81	1.5

**Table 3 Type R Ring Gasket Dimensions and Tolerances (Cont'd)**

Ring Number	Average Pitch Diameter of Ring, $P$	Width of Ring, $A$	Height of Ring		Width of Flat on Octagonal Ring, $C$	Radius in Octagonal Ring, $R_1$
			Oval, $B$	Octagonal, $H$		
R-91	260.35	31.75	...	38.1	22.33	2.3
R-92	228.60	11.13	17.5	16.0	7.75	1.5
R-93	749.30	19.05	...	23.9	12.32	1.5
R-94	800.10	19.05	...	23.9	12.32	1.5
R-95	857.25	19.05	...	23.9	12.32	1.5
R-96	914.40	22.23	...	26.9	14.81	1.5
R-97	965.20	22.23	...	26.9	14.81	1.5
R-98	1 022.35	22.23	...	26.9	14.81	1.5
R-99	234.95	11.13	...	16.0	7.75	1.5
R-100	749.30	28.58	...	35.1	19.81	2.3
R-101	800.10	31.75	...	38.1	22.33	2.3
R-102	857.25	31.75	...	38.1	22.33	2.3
R-103	914.40	31.75	...	38.1	22.33	2.3
R-104	965.20	34.93	...	41.4	24.82	2.3
R-105	1 022.35	34.93	...	41.4	24.82	2.3

## GENERAL NOTES:

(a) All dimensions are in millimeters.

(b) Tolerances:

 $P$  = average pitch diameter of ring,  $\pm 0.18$  $A$  = width of ring,  $\pm 0.20$  $B, H$  = height of ring,  $+1.3, -0.5$ 

Variation in height throughout the entire circumference of any given ring shall not exceed 0.5 within these tolerances.

 $C$  = width of flat on octagonal ring,  $\pm 0.20$  $R_1$  = radius in ring,  $\pm 0.5$ 23 deg = angle,  $\pm 0$  deg 30 min

**Table 4 Pipe Sizes for Type R Ring Gaskets Suitable for Referenced Standards**

Ring Number	Pressure Classes											
	ASME B16.5					API 6B				ASME B16.47 Series A		
	150	300-600	900	1500	2500	720-960 (1)	2000	3000	5000	150	300-600	900
R-11	...	1/2	...	...	...	...	...	...	...	...	...	...
R-12	...	...	1/2	1/2	...	...	...	...	...	...	...	...
R-13	...	3/4	...	...	1/2	...	...	...	...	...	...	...
R-14	...	...	3/4	3/4	...	...	...	...	...	...	...	...
R-15	1	...	...	...	...	...	...	...	...	...	...	...
R-16	...	1	1	1	3/4	1	1	1	1	...	...	...
R-17	1 1/4	...	...	...	...	...	...	...	...	...	...	...
R-18	...	1 1/4	1 1/4	1 1/4	1	1 1/4	1 1/4	1 1/4	1 1/4	...	...	...
R-19	1 1/2	...	...	...	...	...	...	...	...	...	...	...
R-20	...	1 1/2	1 1/2	1 1/2	...	1 1/2	1 1/2	1 1/2	1 1/2	...	...	...
R-21	...	...	...	...	1 1/4	...	...	...	...	...	...	...
R-22	2	...	...	...	...	...	...	...	...	...	...	...
R-23	...	2	...	...	1 1/2	2	2	...	...	...	...	...
R-24	...	...	2	2	...	...	...	2	2	...	...	...
R-25	2 1/2	...	...	...	...	...	...	...	...	...	...	...
R-26	...	2 1/2	...	...	2	2 1/2	2 1/2	...	...	...	...	...
R-27	...	...	2 1/2	2 1/2	...	...	...	2 1/2	2 1/2	...	...	...
R-28	...	...	...	...	2 1/2	...	...	...	...	...	...	...
R-29	3	...	...	...	...	...	...	...	...	...	...	...
R-30 (2)	...	3	...	...	...	...	...	...	...	...	...	...
R-31	...	3	3	...	...	3	3	3	...	...	...	...
R-32	...	...	...	...	3	...	...	...	...	...	...	...
R-33	3 1/2	...	...	...	...	...	...	...	...	...	...	...
R-34	...	3 1/2	...	...	...	...	...	...	...	...	...	...
R-35	...	...	...	3	...	...	...	...	3	...	...	...
R-36	4	...	...	...	...	...	...	...	...	...	...	...
R-37	...	4	4	...	...	4	4	4	3 1/2	...	...	...
R-38	...	...	...	...	4	...	...	...	...	...	...	...
R-39	...	...	...	4	...	...	...	...	4	...	...	...
R-40	5	...	...	...	...	...	...	...	...	...	...	...
R-41	...	5	5	...	...	5	5	5	...	...	...	...
R-42	...	...	...	...	5	...	...	...	...	...	...	...
R-43	6	...	...	...	...	...	...	...	...	...	...	...
R-44	...	...	...	5	...	...	...	...	5	...	...	...
R-45	...	6	6	...	...	6	6	6	...	...	...	...
R-46	...	...	...	6	...	...	...	...	6	...	...	...
R-47	...	...	...	...	6	...	...	...	...	...	...	...
R-48	8	...	...	...	...	...	...	...	...	...	...	...
R-49	...	8	8	...	...	8	8	8	...	...	...	...
R-50	...	...	...	8	...	...	...	...	8	...	...	...
R-51	...	...	...	...	8	...	...	...	...	...	...	...
R-52	10	...	...	...	...	...	...	...	...	...	...	...
R-53	...	10	10	...	...	10	10	10	...	...	...	...
R-54	...	...	...	10	...	...	...	...	10	...	...	...
R-55	...	...	...	...	10	...	...	...	...	...	...	...
R-56	12	...	...	...	...	...	...	...	...	...	...	...
R-57	...	12	12	...	...	12	12	12	...	...	...	...
R-58	...	...	...	12	...	...	...	...	...	...	...	...



**Table 4 Pipe Sizes for Type R Ring Gaskets Suitable for Referenced Standards (Cont'd)**

Ring Number	Pressure Classes											
	ASME B16.5					API 6B				ASME B16.47 Series A		
	150	300-600	900	1500	2500	720-960 (1)	2000	3000	10000 (1)	150	300-600	900
R-59	14	...	...	...	...	...	...	...	...	...	...	...
R-60	...	...	...	...	12	...	...	...	...	...	...	...
R-61	...	14	...	...	...	14	14	14	...	...	...	...
R-62	...	...	14	...	...	...	...	...	...	...	...	...
R-63	...	...	...	14	...	...	...	...	...	...	...	...
R-64	16	...	...	...	...	...	...	...	...	...	...	...
R-65	...	16	...	...	...	16	16	...	...	...	...	...
R-66	...	...	16	...	...	...	...	16	...	...	...	...
R-67	...	...	...	16	...	...	...	...	...	...	...	...
R-68	18	...	...	...	...	...	...	...	...	...	...	...
R-69	...	18	...	...	...	18	18	...	...	...	...	...
R-70	...	...	18	...	...	...	...	18	...	...	...	...
R-71	...	...	...	18	...	...	...	...	...	...	...	...
R-72	20	...	...	...	...	...	...	...	...	...	...	...
R-73	...	20	...	...	...	20	20	...	...	...	...	...
R-74	...	...	20	...	...	...	...	20	...	...	...	...
R-75	...	...	...	20	...	...	...	...	...	...	...	...
R-76	24	...	...	...	...	...	...	...	...	...	...	...
R-77	...	24	...	...	...	...	...	...	...	...	...	...
R-78	...	...	24	...	...	...	...	...	...	...	...	...
R-79	...	...	...	24	...	...	...	...	...	...	...	...
R-80	...	...	...	...	...	...	...	...	...	...	...	...
R-81	...	...	...	...	...	...	...	...	...	...	...	...
R-82	...	...	...	...	...	...	...	...	1	...	...	...
R-84	...	...	...	...	...	...	...	...	1½	...	...	...
R-85	...	...	...	...	...	...	...	...	2	...	...	...
R-86	...	...	...	...	...	...	...	...	2½	...	...	...
R-87	...	...	...	...	...	...	...	...	3	...	...	...
R-88	...	...	...	...	...	...	...	...	4	...	...	...
R-89	...	...	...	...	...	...	...	...	3½	...	...	...
R-90	...	...	...	...	...	...	...	...	5	...	...	...
R-91	...	...	...	...	...	...	...	...	10	...	...	...
R-92	...	...	...	...	...	...	...	...	...	...	...	...
R-93	...	...	...	...	...	...	...	...	...	...	26	...
R-94	...	...	...	...	...	...	...	...	...	...	28	...
R-95	...	...	...	...	...	...	...	...	...	...	30	...
R-96	...	...	...	...	...	...	...	...	...	...	32	...
R-97	...	...	...	...	...	...	...	...	...	...	34	...
R-98	...	...	...	...	...	...	...	...	...	...	36	...
R-99	...	...	...	...	...	...	8	8	...	...	...	...
R-100	...	...	...	...	...	...	...	...	...	...	...	26
R-101	...	...	...	...	...	...	...	...	...	...	...	28
R-102	...	...	...	...	...	...	...	...	...	...	...	30
R-103	...	...	...	...	...	...	...	...	...	...	...	32
R-104	...	...	...	...	...	...	...	...	...	...	...	34
R-105	...	...	...	...	...	...	...	...	...	...	...	36

GENERAL NOTE: End flanges to API 6D and API 600 use gaskets for equivalent pipe size under ASME B16.5 or ASME B16.47 series A.

NOTES:

(1) Class 720, 960, and 10000 flanges to API 6B are obsolete. Data are for information only.

(2) R-30 is for lapped joint only.

Table 5 Type RX Ring Gasket Dimensions and Tolerances

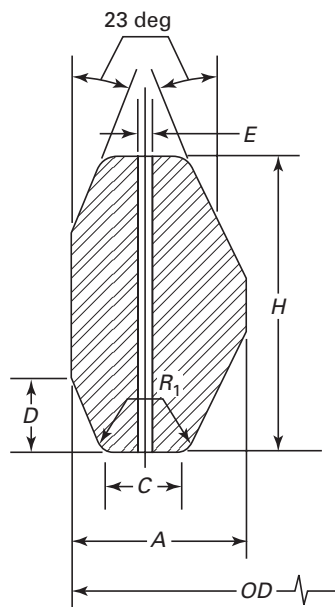

Ring Number	Outside Diameter of Ring, OD	Width of Ring, A	Width of Flat, C	Height of Outside Bevel, D	Height of Ring, H	Radius in Octagonal Ring, R <sub>1</sub>	Hole Size, E [Note (1)]
RX-20	76.20	8.74	4.62	3.18	19.05	1.5	...
RX-23	93.27	11.91	6.45	4.24	25.40	1.5	...
RX-24	105.97	11.91	6.45	4.24	25.40	1.5	...
RX-25	109.55	8.74	4.62	3.18	19.05	1.5	...
RX-26	111.91	11.91	6.45	4.24	25.40	1.5	...
RX-27	118.26	11.91	6.45	4.24	25.40	1.5	...
RX-31	134.54	11.91	6.45	4.24	25.40	1.5	...
RX-35	147.24	11.91	6.45	4.24	25.40	1.5	...
RX-37	159.94	11.91	6.45	4.24	25.40	1.5	...
RX-39	172.64	11.91	6.45	4.24	25.40	1.5	...
RX-41	191.69	11.91	6.45	4.24	25.40	1.5	...
RX-44	204.39	11.91	6.45	4.24	25.40	1.5	...
RX-45	221.84	11.91	6.45	4.24	25.40	1.5	...
RX-46	222.25	13.49	6.68	4.78	28.58	1.5	...
RX-47	245.26	19.84	10.34	6.88	41.28	2.3	...
RX-49	280.59	11.91	6.45	4.24	25.40	1.5	...
RX-50	283.36	16.66	8.51	5.28	31.75	1.5	...
RX-53	334.57	11.91	6.45	4.24	25.40	1.5	...
RX-54	337.34	16.66	8.51	5.28	31.75	1.5	...
RX-57	391.72	11.91	6.45	4.24	25.40	1.5	...
RX-63	441.73	27.00	14.78	8.46	50.80	2.3	...
RX-65	480.62	11.91	6.45	4.24	25.40	1.5	...
RX-66	457.99	16.66	8.51	5.28	31.75	1.5	...
RX-69	544.12	11.91	6.45	4.24	25.40	1.5	...
RX-70	550.06	19.84	10.34	6.88	41.28	2.3	...
RX-73	596.11	13.49	6.68	5.28	31.75	1.5	...
RX-74	600.86	19.84	10.34	6.88	41.28	2.3	...
RX-82	67.87	11.91	6.45	4.24	25.40	1.5	1.5
RX-84	74.22	11.91	6.45	4.24	25.40	1.5	1.5
RX-85	90.09	13.49	6.68	4.24	25.40	1.5	1.5

**Table 5 Type RX Ring Gasket Dimensions and Tolerances (Cont'd)**

Ring Number	Outside Diameter of Ring, <i>OD</i>	Width of Ring, <i>A</i>	Width of Flat, <i>C</i>	Height of Outside Bevel, <i>D</i>	Height of Ring, <i>H</i>	Radius in Octagonal Ring, <i>R</i> <sub>1</sub>	Hole Size, <i>E</i> [Note (1)]
RX-86	103.58	15.09	8.51	4.78	28.58	1.5	2.3
RX-87	113.11	15.09	8.51	4.78	28.58	1.5	2.3
RX-88	139.29	17.48	10.34	5.28	31.75	1.5	3.0
RX-89	129.77	18.26	10.34	5.28	31.75	1.5	3.0
RX-90	174.63	19.84	12.17	7.42	44.45	2.3	3.0
RX-91	286.94	30.18	19.81	7.54	45.24	2.3	3.0
RX-99	245.67	11.91	6.45	4.24	25.40	1.5	...
RX-201	51.46	5.74	3.20	1.45	11.30	0.5 (3)	...
RX-205	62.31	5.56	3.05	1.83 (2)	11.10	0.5 (3)	...
RX-210	97.64	9.53	5.41	3.18 (2)	19.05	0.8 (3)	...
RX-215	140.89	11.91	5.33	4.24 (2)	25.40	1.5 (3)	...

## GENERAL NOTES:

(a) All dimensions are in millimeters.

(b) Tolerances:

*OD* = outside diameter of ring, +0.51, -0.00*A* = width of ring, +0.20, -0.00

Variation in width throughout the entire circumference of any ring shall not exceed 0.10 within these tolerances.

*C* = width of flat, +0.15, -0.00*D* = height of outside bevel, +0.0, -0.76*H* = height of ring, +0.20, -0.00

Variation in height throughout the entire circumference of any ring shall not exceed 0.10 within these tolerances.

*R*<sub>1</sub> = radius of ring, ±0.5

23 deg = angle, ±0 deg 30 min

*E* = hole size, ±0.5

## NOTES:

(1) Rings RX-82 through RX-91 only require one pressure passage hole as illustrated. The centerline of the hole shall be located at the mid-point of dimension *C*.

(2) Tolerance on these dimensions is +0.00, -0.38.

(3) Tolerance on these dimensions is +0.5, -0.0.

**Table 6 Pipe Sizes for Type RX Ring Gaskets Suitable for Referenced Standards**

Ring Number	Pressure Classes, API 6B			
	720–960 and 2000 [Note (1)]	2900 [Note (1)]	3000	5000
RX-20	1½	...	1½	1½
RX-23	2	...	...	...
RX-24	...	...	2	...
RX-25	...	...	...	3¼
RX-26	2½	...	...	...
RX-27	...	...	2½	2½
RX-31	3	...	3	...
RX-35	...	...	...	3
RX-37	4	...	4	...
RX-39	...	...	...	4
RX-41	5	...	5	...
RX-44	...	...	...	5
RX-45	6	...	6	...
RX-46	...	...	...	6
RX-47	...	...	...	8 (2)
RX-49	8	...	8	...
RX-50	...	...	...	8
RX-53	10	...	10	...
RX-54	...	...	...	10
RX-57	12	...	12	...
RX-63	...	...	...	14
RX-65	16	...	...	...
RX-66	...	...	16	...
RX-69	18	...	...	...
RX-70	...	...	18	...
RX-73	20	...	...	...
RX-74	...	...	20	...
RX-82	...	1	...	...
RX-84	...	1½	...	...
RX-85	...	2	...	...
RX-86	...	2½	...	...
RX-87	...	3	...	...
RX-88	...	4	...	...
RX-89	...	3½	...	...
RX-90	...	5	...	...
RX-91	...	10	...	...
RX-99	8 (2)	...	8 (2)	...
RX-201	...	...	...	1¾
RX-205	...	...	...	1 <sup>13</sup> / <sub>16</sub>
RX-210	...	...	...	2 <sup>9</sup> / <sub>16</sub>
RX-215	...	...	...	4 <sup>1</sup> / <sub>16</sub>

## NOTES:

- (1) Class 720, 960, and 2900 flanges to API 6B are obsolete. Data are for information only.  
(2) Crossover flange connection.

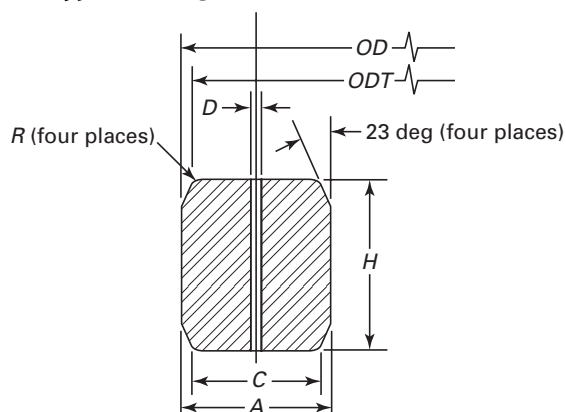
**Table 7 Type BX Ring Gasket Dimensions and Tolerances**

Ring Number	Nominal Size	Outside Diameter of Ring, $OD$	Height of Ring, $H$	Width of Ring, $A$	Outside Diameter of Flat, $ODT$	Width of Flat, $C$	Hole Size, $D$ [Note (1)]
BX-150	43	72.19	9.30	9.30	70.87	7.98	1.5
BX-151	46	76.40	9.63	9.63	75.03	8.26	1.5
BX-152	52	84.68	10.24	10.24	83.24	8.79	1.5
BX-153	65	100.94	11.38	11.38	99.31	9.78	1.5
BX-154	78	116.84	12.40	12.40	115.09	10.64	1.5
BX-155	103	147.96	14.22	14.22	145.95	12.22	1.5
BX-156	179	237.92	18.62	18.62	235.28	15.98	3.0
BX-157	229	294.46	20.98	20.98	291.49	18.01	3.0
BX-158	279	352.04	23.14	23.14	348.77	19.86	3.0
BX-159	346	426.72	25.70	25.70	423.09	22.07	3.0
BX-160	346	402.59	23.83	13.74	399.21	10.36	3.0
BX-161	422	491.41	28.07	16.21	487.45	12.24	3.0
BX-162	422	475.49	14.22	14.22	473.48	12.22	1.5
BX-163	476	556.16	30.10	17.37	551.89	13.11	3.0
BX-164	476	570.56	30.10	24.59	566.29	20.32	3.0
BX-165	540	624.71	32.03	18.49	620.19	13.97	3.0
BX-166	540	640.03	32.03	26.14	635.51	21.62	3.0
BX-167	680	759.36	35.86	13.11	754.28	8.03	1.5
BX-168	680	765.25	35.86	16.05	760.17	10.97	1.5
BX-169	130	173.51	15.85	12.93	171.27	10.69	1.5
BX-170	168	218.03	14.22	14.22	216.03	12.22	1.5
BX-171	218	267.44	14.22	14.22	265.43	12.22	1.5
BX-172	283	333.07	14.22	14.22	331.06	12.22	1.5
BX-303	762	852.75	37.95	16.97	847.37	11.61	1.5

## GENERAL NOTES:

(a) All dimensions are in millimeters.

(b) Radius,  $R$ , shall be 8% to 12% of the gasket height,  $H$ .

(c) Tolerances:

 $OD$  = outside diameter of ring, +0.00, -0.15 $H$  = height of ring, +0.20, -0.00

Variation in height throughout the entire circumference of any ring shall not exceed 0.10 within these tolerances.

 $A$  = width of ring, +0.20, -0.00

Variation in width throughout the entire circumference of any ring shall not exceed 0.10 within these tolerances.

 $ODT$  = outside diameter of flat,  $\pm 0.05$  $C$  = width of flat, +0.15, -0.00 $D$  = hole size,  $\pm 0.5$  $R$  = radius of ring [see General Note (b)]23 deg = angle,  $\pm 0$  deg 15 min

## NOTE:

(1) One pressure passage hole is required per gasket as illustrated. The centerline of the hole shall be located at the midpoint of dimension  $C$ .

**Table 8 Pipe Sizes for Type BX Ring Gaskets Suitable for Referenced Standards**

Ring Number	Pressure Classes, API 6BX					
	2000	3000	5000	10000	15000	20000
BX-150	...	...	...	$1\frac{11}{16}$	$1\frac{11}{16}$	...
BX-151	...	...	...	$1\frac{13}{16}$	$1\frac{13}{16}$	$1\frac{13}{16}$
BX-152	...	...	...	$2\frac{1}{16}$	$2\frac{1}{16}$	$2\frac{1}{16}$
BX-153	...	...	...	$2\frac{9}{16}$	$2\frac{9}{16}$	$2\frac{9}{16}$
BX-154	...	...	...	$3\frac{1}{16}$	$3\frac{1}{16}$	$3\frac{1}{16}$
BX-155	...	...	...	$4\frac{1}{16}$	$4\frac{1}{16}$	$4\frac{1}{16}$
BX-156	...	...	...	$7\frac{1}{16}$	$7\frac{1}{16}$	$7\frac{1}{16}$
BX-157	...	...	...	9	9	9
BX-158	...	...	...	11	11	11
BX-159	...	...	...	$13\frac{5}{8}$	$13\frac{5}{8}$	$13\frac{5}{8}$
BX-160	...	...	$13\frac{5}{8}$	...	...	...
BX-161	...	...	$16\frac{3}{4}$	...	...	...
BX-162	...	...	$16\frac{3}{4}$	$16\frac{3}{4}$	$16\frac{3}{4}$	...
BX-163	...	...	$18\frac{3}{4}$	...	...	...
BX-164	...	...	...	$18\frac{3}{4}$	$18\frac{3}{4}$	...
BX-165	...	...	$21\frac{1}{4}$	...	...	...
BX-166	...	...	...	$21\frac{1}{4}$	...	...
BX-167	$26\frac{3}{4}$	...	...	...	...	...
BX-168	...	$26\frac{3}{4}$	...	...	...	...
BX-169	...	...	...	$5\frac{1}{8}$	...	...
BX-170	...	...	...	$6\frac{5}{8}$	$6\frac{5}{8}$	...
BX-171	...	...	...	$8\frac{9}{16}$	$8\frac{9}{16}$	...
BX-172	...	...	...	$11\frac{7}{32}$	$11\frac{7}{32}$	...
BX-303	30	30	...	...	...	...

Table 9 Dimensions for Spiral-Wound Gaskets Used With ASME B16.5 Flanges

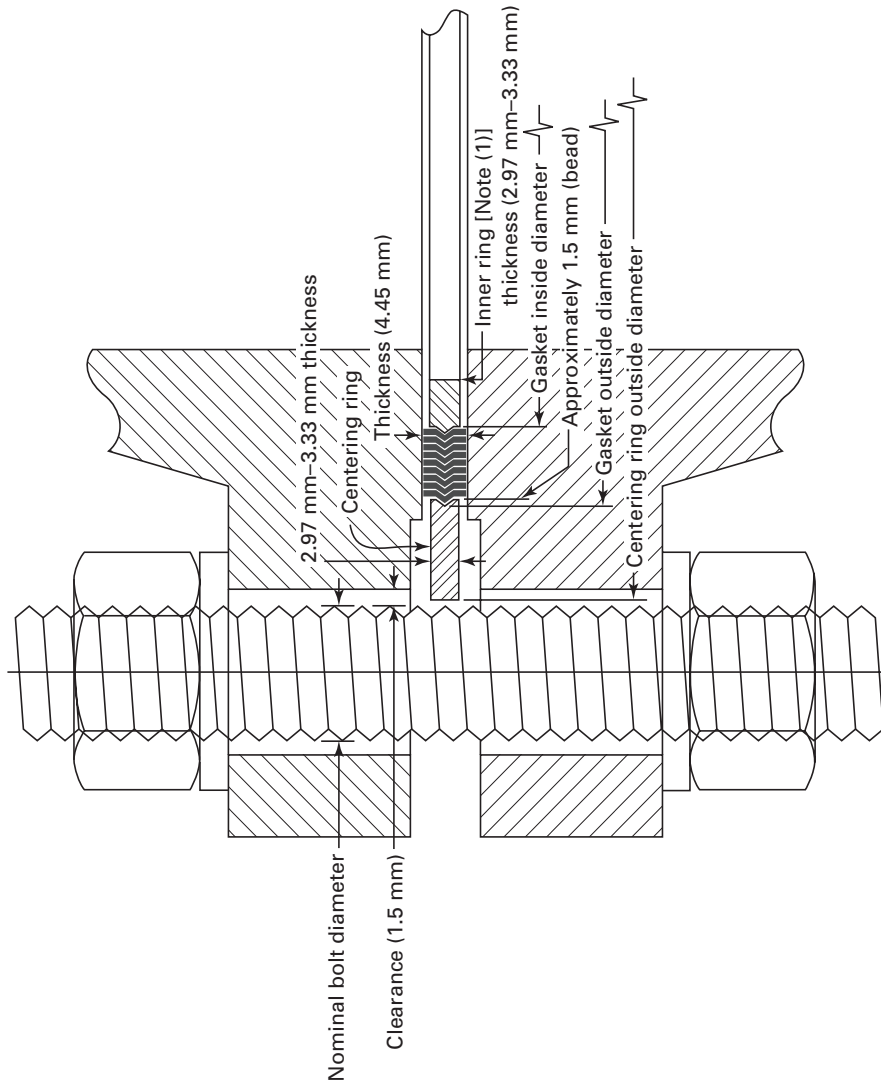

**Table 9 Dimensions for Spiral-Wound Gaskets Used With ASME B16.5 Flanges (Cont'd)**

Flange Size (NPS)	Outside Diameter of Gasket [Note (1)]		Inside Diameter of Gasket by Class [Notes (2), (3)]										Outside Diameter of Centering Ring by Class [Note (4)]				
	Classes 150, 300, 400, 600	Classes 900, 1500, 2500	150	300	400 (5)	600	900 (5)	1500	2500 (5)	150	300	400 (5)	600	900 (5)	1500	2500 (5)	
	1/2	31.8	31.8	19.1	19.1	...	19.1	...	19.1	19.1	47.8	54.1	...	54.1	...	63.5	69.9
3/4	39.6	39.6	25.4	25.4	...	25.4	...	25.4	25.4	57.2	66.8	...	66.8	...	69.9	76.2	
1	47.8	47.8	31.8	31.8	...	31.8	...	31.8	31.8	66.8	73.2	...	73.2	...	79.5	85.9	
1 1/4	60.5	60.5	47.8	47.8	...	47.8	...	39.6	39.6	76.2	82.6	...	82.6	...	88.9	104.9	
1 1/2	69.9	69.9	54.1	54.1	...	54.1	...	47.8	47.8	85.9	95.3	...	95.3	...	98.6	117.6	
2	85.9	85.9	69.9	69.9	...	69.9	...	58.7	58.7	104.9	111.3	...	111.3	...	143.0	146.1	
2 1/2	98.6	98.6	82.6	82.6	...	82.6	...	69.9	69.9	124.0	130.3	...	130.3	...	165.1	168.4	
3	120.7	120.7	101.6	101.6	...	101.6	95.3	92.2	92.2	136.7	149.4	...	149.4	168.4	174.8	196.9	
4	149.4	149.4	127.0	127.0	120.7	120.7	120.7	117.6	117.6	174.8	181.1	177.8	193.8	206.5	209.6	235.0	
5	177.8	177.8	155.7	155.7	147.6	147.6	147.6	143.0	143.0	196.9	215.9	212.9	241.3	247.7	254.0	279.4	
6	209.6	209.6	182.6	182.6	174.8	174.8	174.8	171.5	171.5	222.3	251.0	247.7	266.7	289.1	282.7	317.5	
8	263.7	257.3	233.4	233.4	225.6	225.6	222.3	215.9	215.9	279.4	308.1	304.8	320.8	358.9	352.6	387.4	
10	317.5	311.2	287.3	287.3	274.6	274.6	276.4	266.7	270.0	339.9	362.0	358.9	400.1	435.1	435.1	476.3	
12	374.7	368.3	339.9	339.9	327.2	327.2	323.9	323.9	317.5	409.7	422.4	419.1	457.2	498.6	520.7	549.4	
14	406.4	400.1	371.6	371.6	362.0	362.0	355.6	362.0	...	450.9	485.9	482.6	492.3	520.7	577.9	...	
16	463.6	457.2	422.4	422.4	412.8	412.8	412.8	406.4	...	514.4	539.8	536.7	565.2	574.8	641.4	...	
18	527.1	520.7	474.7	474.7	469.9	469.9	463.6	463.6	...	549.4	596.9	593.9	612.9	638.3	704.9	...	
20	577.9	571.5	525.5	525.5	520.7	520.7	514.4	514.4	...	606.6	654.1	647.7	682.8	698.5	755.7	...	
24	685.8	679.5	628.7	628.7	628.7	628.7	628.7	616.0	...	717.6	774.7	768.4	790.7	838.2	901.7	...	

**GENERAL NOTES:**

- (a) All dimensions are in millimeters.
  - (b) For reference, see Table 9 illustration on previous page.
  - (c) The gasket thickness tolerance is ±13 mm measured across the metallic portion of the gasket, not including the filler, which may protrude slightly beyond the metal.
  - (d) For limitations on the maximum flange bore for use with these spiral-wound gaskets, see Table 16.
- NOTES:**
- (1) The gasket outside diameter tolerance for NPS 1/2 through NPS 8 is ±0.8 mm; for NPS 10 through NPS 24, +1.5 mm, -0.8 mm.
  - (2) Refer to para. 3.2.5 for required use of inner rings.
  - (3) The gasket inside diameter tolerance for NPS 1/2 through NPS 8 is ±0.4 mm; for NPS 10 through NPS 24, ±0.8 mm.
  - (4) The centering ring outside diameter tolerance is ±0.8 mm.
  - (5) There are no Class 400 flanges in NPS 1/2 through NPS 3 (use Class 600), Class 900 flanges in NPS 1/2 through NPS 2 1/2 (use Class 1500), or Class 2500 flanges NPS 14 and larger.



Table 10 Dimensions for Spiral-Wound Gaskets Used With ASME B16.47 Series A Flanges

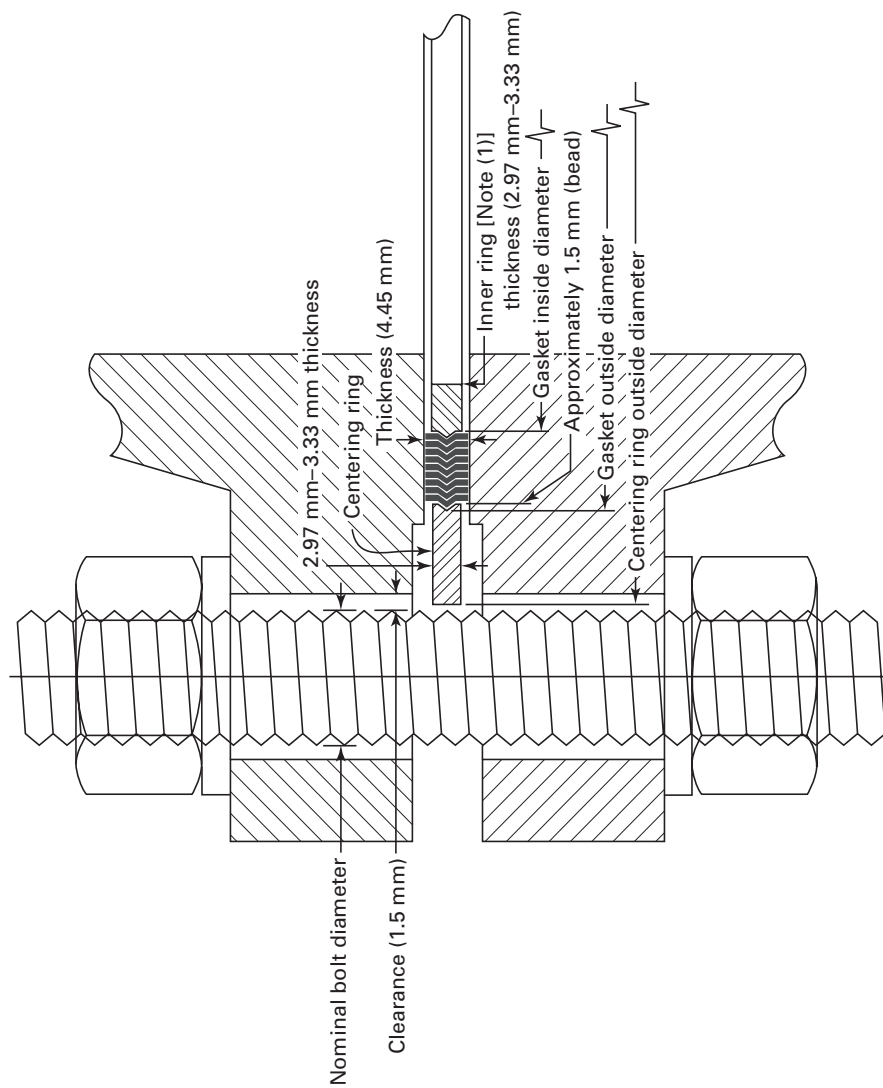

**Table 10 Dimensions for Spiral-Wound Gaskets Used With ASME B16.47 Series A Flanges (Cont'd)**

Flange Size (NPS)	Class 150				Class 300				Class 400				Class 600				Class 900			
	Gasket		Centering Ring		Gasket		Centering Ring		Gasket		Centering Ring		Gasket		Centering Ring		Gasket		Centering Ring	
	Inside Diameter [Notes (1), (2)]	Outside Diameter [Note (3)]	Outside Diameter [Note (4)]	Inside Diameter [Notes (1), (2)]	Outside Diameter [Note (3)]	Outside Diameter [Note (4)]	Inside Diameter [Notes (1), (2)]	Outside Diameter [Note (3)]	Outside Diameter [Note (4)]	Inside Diameter [Notes (1), (2)]	Outside Diameter [Note (3)]	Outside Diameter [Note (4)]	Inside Diameter [Notes (1), (2)]	Outside Diameter [Note (3)]	Outside Diameter [Note (4)]	Inside Diameter [Notes (1), (2)]	Outside Diameter [Note (3)]	Outside Diameter [Note (4)]	Inside Diameter [Notes (1), (2)]	Outside Diameter [Notes (3), (4), (5)]
26	673.1	704.9	774.7	685.8	736.6	835.2	685.8	736.6	831.9	685.8	736.6	866.9	685.8	736.6	882.7					
28	723.9	755.7	831.9	736.6	787.4	898.7	736.6	787.4	892.3	736.6	787.4	914.4	736.6	787.4	946.2					
30	774.7	806.5	882.7	793.8	844.6	952.5	793.8	844.6	946.2	793.8	844.6	971.6	793.8	844.6	1 009.7					
32	825.5	860.6	939.8	850.9	901.7	1 006.6	850.9	901.7	1 003.3	850.9	901.7	1 022.4	850.9	901.7	1 073.2					
34	876.3	911.4	990.6	901.7	952.5	1 057.4	901.7	952.5	1 054.1	901.7	952.5	1 073.2	901.7	952.5	1 136.7					
36	927.1	968.5	1 047.8	955.8	1 006.6	1 117.6	955.8	1 006.6	1 117.6	955.8	1 006.6	1 130.3	958.9	1 009.7	1 200.2					
38	977.9	1 019.3	1 111.3	977.9	1 016.0	1 054.1	971.6	1 022.4	1 073.2	990.6	1 041.4	1 104.9	1 035.1	1 085.9	1 200.2					
40	1 028.7	1 070.1	1 162.1	1 022.4	1 070.1	1 114.6	1 025.7	1 076.5	1 127.3	1 047.8	1 098.6	1 155.7	1 098.6	1 149.4	1 251.0					
42	1 079.5	1 124.0	1 219.2	1 073.2	1 120.9	1 165.4	1 076.5	1 127.3	1 178.1	1 104.9	1 155.7	1 219.2	1 149.4	1 200.2	1 301.8					
44	1 130.3	1 178.1	1 276.4	1 130.3	1 181.1	1 219.2	1 130.3	1 181.1	1 231.9	1 162.1	1 212.9	1 270.0	1 206.5	1 257.3	1 368.6					
46	1 181.1	1 228.9	1 327.2	1 178.1	1 228.9	1 273.3	1 193.8	1 244.6	1 289.1	1 212.9	1 263.7	1 327.2	1 270.0	1 320.8	1 435.1					
48	1 231.9	1 279.7	1 384.3	1 235.2	1 286.0	1 324.1	1 244.6	1 295.4	1 346.2	1 270.0	1 320.8	1 390.7	1 320.8	1 371.6	1 485.9					
50	1 282.7	1 333.5	1 435.1	1 295.4	1 346.2	1 378.0	1 295.4	1 346.2	1 403.4	1 320.8	1 371.6	1 447.8	...	...	...					
52	1 333.5	1 384.3	1 492.3	1 346.2	1 397.0	1 428.8	1 346.2	1 397.0	1 454.2	1 371.6	1 422.4	1 498.6	...	...	...					
54	1 384.3	1 435.1	1 549.4	1 403.4	1 454.2	1 492.3	1 403.4	1 454.2	1 517.7	1 428.8	1 479.6	1 555.8	...	...	...					
56	1 435.1	1 485.9	1 606.6	1 454.2	1 505.0	1 543.1	1 454.2	1 505.0	1 568.5	1 479.6	1 530.4	1 612.9	...	...	...					
58	1 485.9	1 536.7	1 663.7	1 511.3	1 562.1	1 593.9	1 505.0	1 555.8	1 619.3	1 536.7	1 587.5	1 663.7	...	...	...					
60	1 536.7	1 587.5	1 714.5	1 562.1	1 612.9	1 644.7	1 568.5	1 619.3	1 682.8	1 593.9	1 644.7	1 733.6	...	...	...					

GENERAL NOTES:

- (a) All dimensions are in millimeters.
- (b) For reference, see Table 10 illustration on previous page.
- (c) The gasket thickness tolerance is  $\pm 0.13$  mm measured across the metallic portion of the gasket, not including the filler, which may protrude slightly beyond the metal.
- (d) For limitations on the maximum flange bore for use with these spiral-wound gaskets, see Table 17.
- (e) ASME B16.47 Series A flanges NPS 12 through NPS 24 have the same raised face dimensions as ASME B16.5 flanges.

NOTES:

- (1) Refer to para. 3.2.5 for required use of inner rings.
- (2) The gasket inside diameter tolerance for NPS 26 through NPS 34 is  $\pm 0.8$  mm, and the tolerance for NPS 36 through NPS 60 is  $\pm 1.3$  mm.
- (3) The gasket outside diameter tolerance for NPS 26 through NPS 60 is  $\pm 1.5$  mm.
- (4) The centering ring outside diameter tolerance is  $\pm 0.8$  mm.
- (5) There are no Class 900 flanges NPS 50 and larger.

Table 11 Dimensions for Spiral-Wound Gaskets Used With ASME B16.47 Series B Flanges

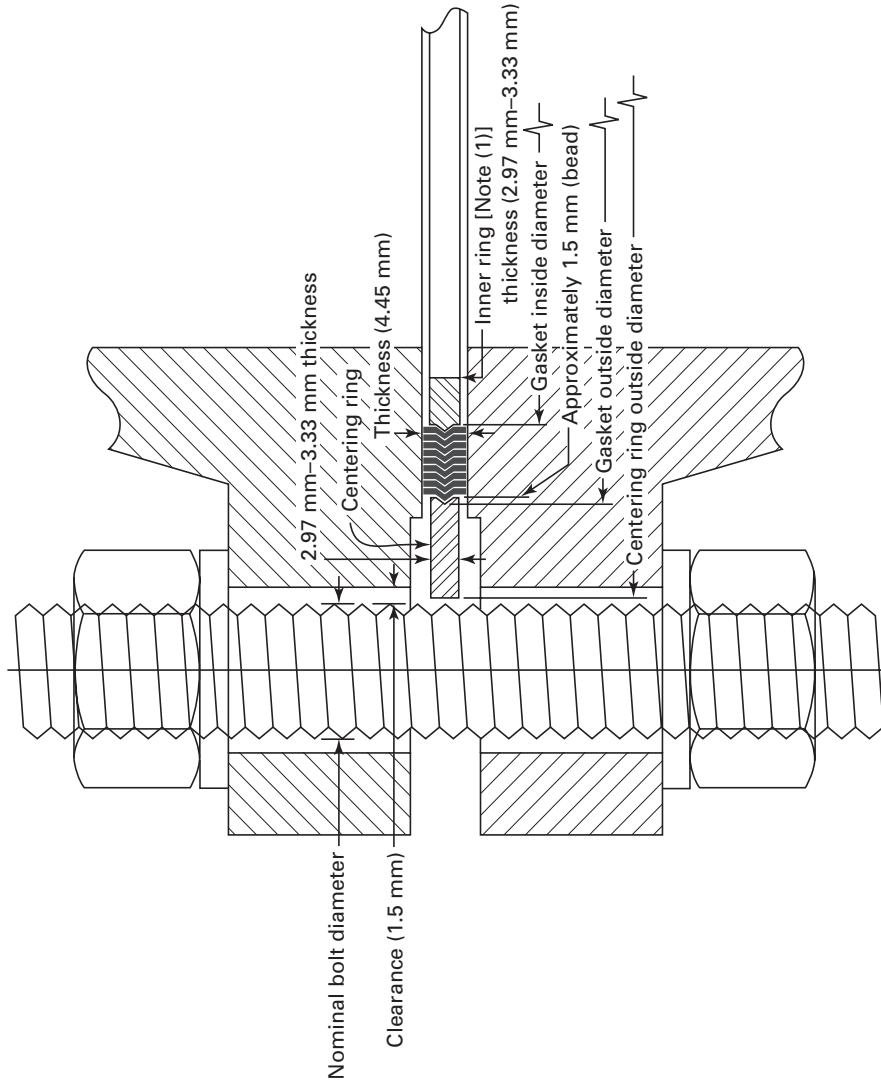

**Table 11 Dimensions for Spiral-Wound Gaskets Used With ASME B16.47 Series B Flanges (Cont'd)**

Flange Size (NPS)	Class 150				Class 300				Class 400				Class 600				Class 900			
	Gasket		Centering Ring		Gasket		Centering Ring		Gasket		Centering Ring		Gasket		Centering Ring		Gasket		Centering Ring	
	Inside Diameter [Notes (1), (2)]	Outside Diameter [Note (3)]	Inside Diameter [Notes (1), (2)]	Outside Diameter [Note (4)]	Inside Diameter [Notes (1), (2)]	Outside Diameter [Note (3)]	Inside Diameter [Notes (1), (2)]	Outside Diameter [Note (4)]	Inside Diameter [Notes (1), (2)]	Outside Diameter [Note (3)]	Inside Diameter [Notes (1), (2)]	Outside Diameter [Note (4)]	Inside Diameter [Notes (1), (2)]	Outside Diameter [Note (3)]	Inside Diameter [Notes (1), (2)]	Outside Diameter [Note (4)]	Inside Diameter [Notes (1), (2)]	Outside Diameter [Note (5)]	Inside Diameter [Notes (1), (2)]	Outside Diameter [Notes (3), (4), (5)]
26	673.1	698.5	725.4	771.2	771.7	666.8	698.5	746.3	746.3	663.7	714.5	765.3	692.2	749.3	838.2					
28	723.9	749.3	776.2	825.5	825.5	714.5	749.3	800.1	800.1	704.9	755.7	819.2	743.0	800.1	901.7					
30	774.7	800.1	827.0	886.0	886.0	765.3	806.5	857.3	857.3	778.0	828.8	879.6	806.5	857.3	958.9					
32	825.5	850.9	881.1	939.8	939.8	812.8	860.6	911.4	911.4	831.9	882.7	933.5	863.6	914.4	1 016.0					
34	876.3	908.1	935.0	993.9	993.9	866.9	911.4	962.2	962.2	889.0	939.8	997.0	920.8	971.6	1 073.2					
36	927.1	958.9	987.6	1 047.8	1 047.8	917.7	965.2	1 022.4	1 022.4	939.8	990.6	1 047.8	946.2	997.0	1 124.0					
38	974.9	1 009.7	1 044.7	1 109.7	1 109.7	971.6	1 022.4	1 073.2	1 073.2	990.6	1 041.4	1 104.9	1 035.1	1 085.9	1 200.2					
40	1 022.4	1 063.8	1 095.5	1 149.4	1 149.4	1 025.7	1 076.5	1 127.3	1 127.3	1 047.8	1 098.6	1 155.7	1 098.6	1 149.4	1 251.0					
42	1 079.5	1 114.6	1 146.3	1 199.4	1 199.4	1 076.5	1 127.3	1 178.1	1 178.1	1 104.9	1 155.7	1 219.2	1 149.4	1 200.2	1 301.8					
44	1 124.0	1 165.4	1 197.1	1 251.0	1 251.0	1 130.3	1 181.1	1 231.9	1 231.9	1 162.1	1 212.9	1 270.0	1 206.5	1 257.3	1 368.6					
46	1 181.1	1 224.0	1 255.8	1 317.8	1 317.8	1 193.8	1 244.6	1 289.1	1 289.1	1 212.9	1 263.7	1 327.2	1 270.0	1 320.8	1 435.1					
48	1 231.9	1 270.0	1 306.6	1 368.6	1 368.6	1 244.6	1 295.4	1 346.2	1 346.2	1 270.0	1 320.8	1 390.7	1 320.8	1 371.6	1 485.9					
50	1 282.7	1 325.6	1 357.4	1 419.4	1 419.4	1 295.4	1 346.2	1 403.4	1 403.4	1 320.8	1 371.6	1 447.8	...	...	...					
52	1 333.5	1 376.4	1 408.2	1 470.2	1 470.2	1 346.2	1 397.0	1 454.2	1 454.2	1 371.6	1 422.4	1 498.6	...	...	...					
54	1 384.3	1 422.4	1 463.8	1 530.4	1 530.4	1 403.4	1 454.2	1 517.7	1 517.7	1 428.8	1 479.6	1 555.8	...	...	...					
56	1 444.8	1 478.0	1 514.6	1 579.6	1 579.6	1 454.2	1 505.0	1 568.5	1 568.5	1 479.6	1 530.4	1 612.9	...	...	...					
58	1 500.1	1 528.8	1 579.6	1 630.4	1 630.4	1 505.0	1 555.8	1 619.3	1 619.3	1 536.7	1 587.5	1 663.7	...	...	...					
60	1 557.3	1 586.0	1 630.4	1 693.9	1 693.9	1 568.5	1 619.3	1 682.8	1 682.8	1 593.9	1 644.7	1 733.6	...	...	...					

**GENERAL NOTES:**

- (a) All dimensions are in millimeters.
- (b) For reference, see Table 11 illustration on previous page.
- (c) The gasket thickness tolerance is ±0.13 mm measured across the metallic portion of the gasket, not including the filler, which may protrude slightly beyond the metal.
- (d) For limitations on the maximum flange bore for use with these spiral-wound gaskets, see Table 18.

**NOTES:**

- (1) Refer to para. 3.2.5 for required use of inner rings.
- (2) The gasket inside diameter tolerance for NPS 26 through NPS 34 is ±0.8 mm, and the tolerance for NPS 36 through NPS 60 is ±1.3 mm.
- (3) The gasket outside diameter tolerance for NPS 26 through NPS 60 is ±1.5 mm.
- (4) The centering ring outside diameter tolerance is ±0.8 mm.
- (5) There are no Class 900 flanges NPS 50 and larger.

**Table 12 Inner-Ring Inside Diameters for Spiral-Wound Gaskets for Use With ASME B16.5 Flanges**

Flange Size (NPS)	Pressure Class						
	150	300	400 [Note (1)]	600	900 [Note (1)]	1500	2500 [Note (1)]
1/2	14.2	14.2	...	14.2	...	14.2	14.2
3/4	20.6	20.6	...	20.6	...	20.6	20.6
1	26.9	26.9	...	26.9	...	26.9	26.9
1 1/4	38.1	38.1	...	38.1	...	33.3	33.3
1 1/2	44.5	44.5	...	44.5	...	41.4	41.4
2	55.6	55.6	...	55.6	...	52.3	52.3
2 1/2	66.5	66.5	...	66.5	...	63.5	63.5
3	81.0	81.0	...	81.0	78.7	78.7	78.7
4	106.4	106.4	102.6	102.6	102.6	97.8	97.8
5	131.8	131.8	128.3	128.3	128.3	124.5	124.5
6	157.2	157.2	154.9	154.9	154.9	147.3	147.3
8	215.9	215.9	205.7	205.7	196.9	196.9	196.9
10	268.2	268.2	255.3	255.3	246.1	246.1	246.1
12	317.5	317.5	307.3	307.3	292.1	292.1	292.1
14	349.3	349.3	342.9	342.9	320.8	320.8	...
16	400.1	400.1	389.9	389.9	374.7	368.3	...
18	449.3	449.3	438.2	438.2	425.5	425.5	...
20	500.1	500.1	489.0	489.0	482.6	476.3	...
24	603.3	603.3	590.6	590.6	590.6	577.9	...

## GENERAL NOTES:

- (a) All dimensions are in millimeters.  
 (b) The inner-ring thickness shall be 2.97 mm to 3.33 mm.  
 (c) For sizes NPS 1/2 through NPS 3, the inside diameter tolerance is  $\pm 0.8$  mm; for larger sizes the inside diameter tolerance is  $\pm 1.5$  mm. See Table 15 for minimum pipe wall thicknesses that are suitable for use with standard inner rings.  
 (d) Refer to para. 3.2.5 for required use of inner rings.

## NOTE:

- (1) There are no NPS 1/2 through NPS 3 Class 400 flanges (use Class 600), NPS 1/2 through NPS 2 1/2 Class 900 flanges (use Class 1500), or NPS 14 and larger Class 2500 flanges.

**Table 13 Inner-Ring Inside Diameters for Spiral-Wound Gaskets Used Between ASME B16.47 Series A Flanges**

Flange Size (NPS)	Pressure Class				
	150	300	400	600	900 [Note (1)]
26	654.1	654.1	660.4	647.7	660.4
28	704.9	704.9	711.2	698.5	711.2
30	755.7	755.7	755.7	755.7	768.4
32	806.5	806.5	812.8	812.8	812.8
34	857.3	857.3	863.6	863.6	863.6
36	908.1	908.1	917.7	917.7	920.8
38	958.9	952.5	952.5	952.5	1 009.7
40	1 009.7	1 003.3	1 000.3	1 009.7	1 060.5
42	1 060.5	1 054.1	1 051.1	1 066.8	1 111.3
44	1 111.3	1 104.9	1 104.9	1 111.3	1 155.7
46	1 162.1	1 152.7	1 168.4	1 162.1	1 219.2
48	1 212.9	1 209.8	1 206.5	1 219.2	1 270.0
50	1 263.7	1 244.6	1 257.3	1 270.0	...
52	1 314.5	1 320.8	1 308.1	1 320.8	...
54	1 358.9	1 352.6	1 352.6	1 378.0	...
56	1 409.7	1 403.4	1 403.4	1 428.8	...
58	1 460.5	1 447.8	1 454.2	1 473.2	...
60	1 511.3	1 524.0	1 517.7	1 530.4	...

## GENERAL NOTES:

- (a) All dimensions are in millimeters.
- (b) The inner-ring thickness shall be 2.97 mm to 3.33 mm.
- (c) The inside diameter tolerance is  $\pm 3.0$  mm.
- (d) These inner rings are suitable for use with pipe walls 9.53 mm or thicker.
- (e) Refer to para. 3.2.5 for required use of inner rings.

## NOTE:

- (1) There are no Class 900 flanges NPS 50 and larger.

**Table 14 Inner-Ring Inside Diameters for Spiral-Wound Gaskets Used Between ASME B16.47 Series B Flanges**

Flange Size (NPS)	Pressure Class				
	150	300	400	600	900 [Note (1)]
26	654.1	654.1	654.1	644.7	666.8
28	704.9	704.9	701.8	685.8	717.6
30	755.7	755.7	752.6	752.6	781.1
32	806.5	806.5	800.1	793.8	838.2
34	857.3	857.3	850.9	850.9	895.4
36	908.1	908.1	898.7	901.7	920.8
38	958.9	971.6	952.5	952.5	1 009.7
40	1 009.7	1 022.4	1 000.3	1 009.7	1 060.5
42	1 060.5	1 085.9	1 051.1	1 066.8	1 111.3
44	1 111.3	1 124.0	1 104.9	1 111.3	1 155.7
46	1 162.1	1 178.1	1 168.4	1 162.1	1 219.2
48	1 212.9	1 231.9	1 206.5	1 219.2	1 270.0
50	1 263.7	1 267.0	1 257.3	1 270.0	...
52	1 314.5	1 317.8	1 308.1	1 320.8	...
54	1 365.3	1 365.3	1 352.6	1 378.0	...
56	1 422.4	1 428.8	1 403.4	1 428.8	...
58	1 478.0	1 484.4	1 454.2	1 473.2	...
60	1 535.2	1 557.3	1 517.7	1 530.4	...

## GENERAL NOTES:

- (a) All dimensions are in millimeters.
- (b) The inner-ring thickness shall be 2.97 mm to 3.33 mm.
- (c) The inside diameter tolerance is  $\pm 3.0$  mm.
- (d) These inner rings are suitable for use with pipe walls 9.53 mm or thicker.
- (e) Refer to para. 3.2.5 for required use of inner rings.

## NOTE:

- (1) There are no Class 900 flanges NPS 50 and larger.

**Table 15 Minimum Pipe Wall Thickness Suitable for Use of Spiral-Wound Gaskets With Inner Rings for ASME B16.5 Flanges**

Flange Size (NPS)	Pressure Class						
	150	300	400	600	900	1500	2500
1/2	Schedule 80						
3/4							
1							
1 1/4	Schedule 40					Schedule 80	
1 1/2							
2							
2 1/2							
3							
4							
5	Schedule 80						
6							
8	Schedule 10S		Schedule 30		Schedule 80		
10							
12							
14							
16							
18							
20							
24							

GENERAL NOTES:

- (a) The pipe wall schedules identified represent the minimum recommended pipe wall thickness suitable for use with inner rings for ASME B16.5 flanges. (Reference ASME B36.10M and B36.19M.)
- (b) Gaskets with inner rings should be used only with socket welding, lapped, welding neck, and integral flanges.
- (c) Refer to para. 3.2.5 for required use of inner rings.



**Table 16 Maximum Bore of ASME B16.5 Flanges for Use With Spiral-Wound Gaskets**

Flange Size (NPS)	Pressure Class							
	75	150	300	400	600	900 (1)	1500 (1)	2500 (1)
1/2	No flanges	WN flange only (2)	SO flange WN flange, any bore	No flanges Use Class 600	WN flange only (2)	No flanges Use Class 1500	WN flange only (2)	
3/4		SO flange (3) WN flange (2)			SO flange (3) WN flange (2)			
1		SO flange (3) WN flange, any bore			SO flange (3) WN flange, any bore			
1 1/4								
1 1/2								
2								
2 1/2								
3								
4								
6								
8								
10								
12								
14								
16								
18								
20								
24								

**GENERAL NOTES:**

- (a) This Table shows the maximum bore of flanges for which the spiral-wound gasket dimensions shown in Table 9 are recommended, considering the tolerances involved, possible eccentric installation, and the possibility that the gasket may extend into the assembled flange bore.
- (b) For maximum permissible flange bores for nonmandatory inner rings, see Table 15.
- (c) Abbreviations: SO = slip on and threaded, WN = welding neck, and SW = standard wall.

**NOTES:**

- (1) Refer to para. 3.2.5 for required use of inner rings. These inner rings may extend into the pipe bore a maximum of 1.5 mm under the worst combination of maximum bore, eccentric installation, and additive tolerances.
- (2) In these sizes, the gasket is suitable for a welding neck flange with a standard wall bore, if the gasket and the flanges are assembled concentrically. This also applies to a nozzle. It is the user's responsibility to determine if the gasket is satisfactory for a flange of any larger bore.
- (3) Gaskets in these sizes are suitable for slip-on flanges only if the gaskets and flanges are assembled concentrically.
- (4) A *nozzle* is a long welding neck; the bore equals the flange NPS.
- (5) An NPS 24 gasket is suitable for nozzles.

**Table 17 Maximum Bore of ASME B16.47 Series A Flanges for Use With Spiral-Wound Gaskets**

Flange Size (NPS)	Pressure Class				
	150	300	400	600	900
26	(1)	(2)	(2)	(2)	(2)
28	(1)	(2)	(2)	(2)	(2)
30	(1)	(2)	(2)	(2)	(2)
32	(1)	(2)	(2)	(2)	(2)
34	(1)	(2)	(2)	(2)	(2)
36	(1)	(2)	(2)	(2)	(2)
38	(1)	(2)	(2)	(2)	(2)
40	(1)	(2)	(2)	(2)	(2)
42	(1)	(2)	(2)	(2)	(2)
44	(1)	(2)	(2)	(2)	(2)
46	(1)	(2)	(2)	(2)	(2)
48	(1)	(2)	(2)	(2)	(2)
50	(1)	(2)	(2)	(2)	(3)
52	(1)	(2)	(2)	(2)	(3)
56	(1)	(2)	(2)	(2)	(3)
58	(1)	(2)	(2)	(2)	(3)
60	(1)	(2)	(2)	(2)	(3)

## GENERAL NOTES:

- (a) This Table shows the maximum bore of flanges for which the spiral-wound gasket dimensions shown in Table 10 are recommended, considering the tolerances involved, the possibility of eccentric installation, and the possibility that the gasket may extend into the assembled flange bore.
- (b) Refer to para. 3.2.5 for required use of inner rings.

## NOTES:

- (1) Applies only to welding neck flanges with a bore not larger than the inside diameter of a 4.75-mm wall pipe. Larger bores must be checked individually.
- (2) Applies only to welding neck flanges with a bore not larger than the inside diameter of a 6.4-mm wall pipe, except that NPS 38, Class 300, is not suitable for a bore larger than the inside diameter of a 7.6-mm wall pipe. Larger bores must be checked individually.
- (3) There are no Class 900 flanges NPS 50 and larger.

**Table 18 Maximum Bore of ASME B16.47 Series B Flanges for Use With Spiral-Wound Gaskets**

Flange Size (NPS)	Pressure Class				
	150	300	400	600	900 [Note (1)]
26					
28					
30					
32					
34					
36					
38					
40	Welding neck and integral flanges having maximum inside diameters as described in ASME B16.47				
44					
46					
48					
50					
52					(1)
54					(1)
56					(1)
58					(1)
60					(1)

GENERAL NOTES:

(a) This Table shows the maximum bore of flanges for which the spiral-wound gasket dimensions shown in Tables 11 and I-6 are recommended, considering the tolerances involved, the possibility of eccentric installation, and the possibility that the gasket may extend into the assembled flange bore.

(b) Refer to para. 3.2.5 for required use of inner rings.

NOTE:

(1) There are no Class 900 flanges NPS 50 and larger.

**Table 19 Color Coding and Abbreviations for Spiral-Wound Gasket Materials**

Material	Abbreviation	Color Code
<b>Metallic Winding Materials</b>		
Carbon steel	CRS	Silver
304 SS	304	Yellow
304 L SS	304 L	No color
309 SS	309	No color
310 SS	310	No color
316 L SS	316 L	Green
317 L SS	317 L	Maroon
347 SS	347	Blue
321 SS	321	Turquoise
430 SS	430	No color
Ni-Cu	...	...
Monel 400	MON	Orange
Grade 400	...	...
Nickel 200	NI	Red
Titanium	TI	Purple
20Cb-3 alloy	A-20	Black
Ni-Mo	...	...
Hastelloy B	HAST B	Brown
Grade B2	...	...
Ni-Mo-Cr	...	...
Hastelloy C	HAST C	Beige
Grade C-276	...	...
Ni-Cr-Fe	...	...
Inconel 600	INC 600	Gold
Grade 600	...	...
Ni-Cr-Fe-Cb	...	...
Inconel 625	INC 625	Gold
Grade 625	...	...
Ni-Cr-Fe-Ti	...	...
Inconel X-750	INX	No color
Grade X-750	...	...
Ni-Fe-Cr	...	...
Incoloy 800	IN 800	White
Grade 800	...	...
Ni-Fe-Cr-Mo-Cu	...	...
Incoloy 825	IN 825	White
Grade 825	...	...
Zirconium	ZIRC	No color
<b>Nonmetallic Filler Materials</b>		
Chrysotile asbestos	ASB	No stripe
Polytetrafluoroethylene	PTFE	White stripe
Mica-graphite	Manufacturer's designation	Pink stripe
Flexible graphite	F.G.	Gray stripe
Ceramic	CER	Light green stripe

**Table 20 Example Markings for Spiral-Wound Gaskets**

Description	Marking
NPS 3, Class 300 and 600 ASME B16.5 gasket having a Type 304 metal winding and a flexible graphite filler material	3-300/600-F.G. (Manufacturer's trademark) ASME B16.20
NPS 36, Class 300 ASME B16.47 Series A gasket having a Type 304 metal winding and a ceramic filler material	36-300-CER ASME B16.47 A (Manufacturer's trademark) ASME B16.20
NPS 12, Class 1500 ASME B16.5 gasket having an inconel metal winding, PTFE filler material, and an inconel inner ring	12-1500 INC 600-PTFE INC 600 I.R. (Manufacturer's trademark) ASME B16.20

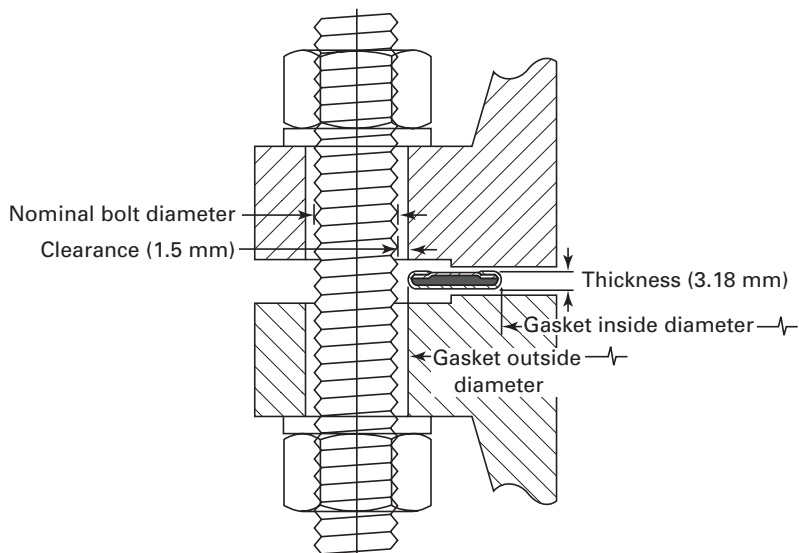
**Table 21 Jacketed Gasket Dimensions for ASME B16.5 Flanges**

Flange Size (NPS)	Gasket Inside Diameter [Note (1)]	Gasket Outside Diameter by Class [Note (1)]						
		150	300	400 [Note (2)]	600	900 [Note (2)]	1500	2500 [Note (2)]
1/2	22.4	44.5	50.8	...	50.8	...	60.5	66.8
3/4	28.7	54.1	63.5	...	63.5	...	66.8	73.2
1	38.1	63.5	69.9	...	69.9	...	76.2	82.6
1 1/4	47.8	73.2	79.5	...	79.5	...	85.9	101.6
1 1/2	54.1	82.6	92.2	...	92.2	...	95.3	114.3
2	73.2	101.6	108.0	...	108.0	...	139.7	143.0
2 1/2	85.9	120.7	127.0	...	127.0	...	162.1	165.1
3	108.0	133.4	146.1	...	146.1	165.1	171.5	193.8
4	131.8	171.5	177.8	174.8	190.5	203.2	206.5	231.9
5	152.4	193.8	212.9	209.6	238.3	244.6	251.0	276.4
6	190.5	219.2	247.7	244.6	263.7	285.8	279.4	314.5
8	238.3	276.4	304.8	301.8	317.5	355.6	349.3	384.3
10	285.8	336.6	358.9	355.6	397.0	431.8	431.8	473.2
12	342.9	406.4	419.1	416.1	454.2	495.3	517.7	546.1
14	374.7	447.8	482.6	479.6	489.0	517.7	574.8	...
16	425.5	511.3	536.7	533.4	562.1	571.5	638.3	...
18	489.0	546.1	593.9	590.6	609.6	635.0	701.8	...
20	533.4	603.3	651.0	644.7	679.5	695.5	752.6	...
24	641.4	714.5	771.7	765.3	787.4	835.2	898.7	...

## GENERAL NOTES:

- (a) All dimensions are in millimeters.  
 (b) The gasket thickness tolerance is +0.8 mm, -0.0 mm.

## NOTES:

- (1) For gaskets NPS 1/2 through NPS 24, the outside and inside diameter tolerances are +1.5 mm, -0.0 mm.  
 (2) There are no Class 400 flanges NPS 1/2 through NPS 3 (use Class 600), Class 900 flanges NPS 1/2 through NPS 2 1/2 (use Class 1500), or Class 2500 flanges NPS 14 and larger.

**Table 22 Jacketed Gasket Dimensions for  
ASME B16.47 Series A Flanges**

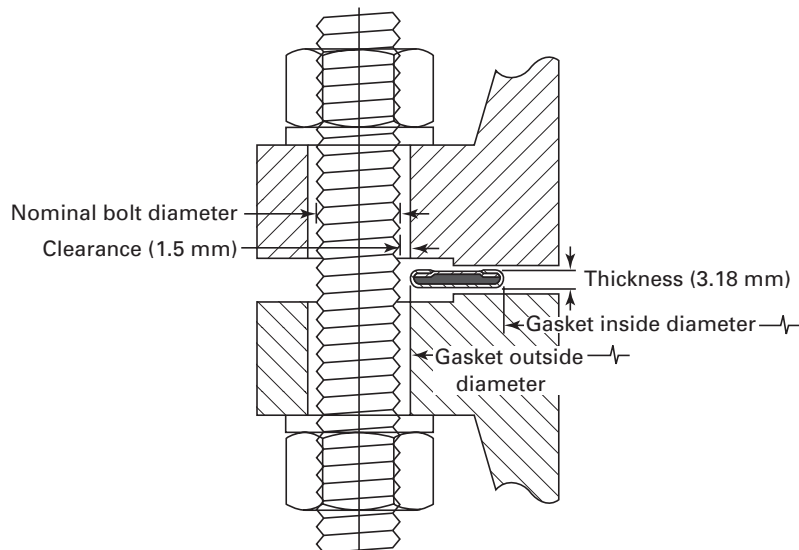

Flange Size (NPS)	Gasket Inside Diameter [Note (1)]	Gasket Outside Diameter by Class [Note (1)]				
		150	300	400	600	900 [Note (2)]
26	673.1	771.7	831.9	828.8	863.6	879.6
28	723.9	828.8	895.4	889.0	911.4	943.1
30	774.7	879.6	949.5	943.1	968.5	1 006.6
32	825.5	936.8	1 003.3	1 000.3	1 019.3	1 070.1
34	876.3	987.6	1 054.1	1 051.1	1 070.1	1 133.6
36	927.1	1 044.7	1 114.6	1 114.6	1 127.3	1 197.1
38	977.9	1 108.2	1 051.1	1 070.1	1 101.9	1 197.1
40	1 028.7	1 159.0	1 111.3	1 124.0	1 152.7	1 247.9
42	1 079.5	1 216.2	1 162.1	1 174.8	1 216.2	1 298.7
44	1 130.3	1 273.3	1 216.2	1 228.9	1 267.0	1 365.3
46	1 181.1	1 324.1	1 270.0	1 286.0	1 324.1	1 432.1
48	1 231.9	1 381.3	1 320.8	1 343.2	1 387.6	1 482.9
50	1 282.7	1 432.1	1 374.9	1 400.3	1 444.8	...
52	1 333.5	1 489.2	1 425.7	1 451.1	1 495.6	...
54	1 384.3	1 546.4	1 489.2	1 514.6	1 552.7	...
56	1 435.1	1 603.5	1 540.0	1 565.4	1 603.5	...
58	1 485.9	1 660.7	1 590.8	1 616.2	1 660.7	...
60	1 536.7	1 711.5	1 641.6	1 679.7	1 730.5	...

## GENERAL NOTES:

- (a) All dimensions are in millimeters.  
 (b) The gasket thickness tolerance is +0.8 mm, -0.0 mm.

## NOTES:

- (1) For gaskets NPS 26 through NPS 60, the outside diameter and inside diameter tolerances are +3.3 mm, -0.0 mm.  
 (2) There are no Class 900 flanges NPS 50 and larger.

**Table 23 Jacketed Gasket Dimensions for ASME B16.47 Series B Flanges**

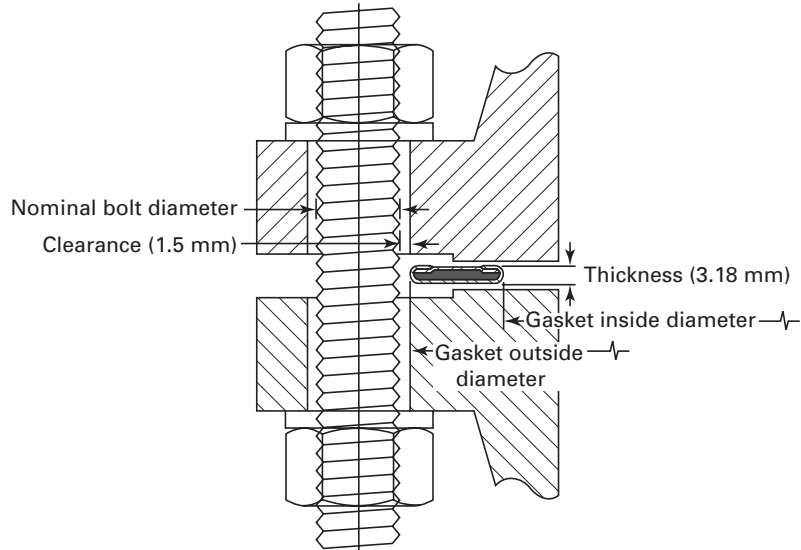

Flange Size (NPS)	Gasket Inside Diameter [Note (1)]	Gasket Outside Diameter by Class [Note (1)]				
		150	300	400	600	900 [Note (2)]
26	673.1	722.4	768.4	743.0	762.0	835.2
28	723.9	773.2	822.5	797.1	816.1	898.7
30	774.7	824.0	882.7	854.2	876.3	955.8
32	825.5	877.8	936.8	908.1	930.4	1 013.0
34	876.3	931.9	990.6	958.9	993.9	1 070.1
36	927.1	984.3	1 044.7	1 019.3	1 044.7	1 120.9
38	977.9	1 041.4	1 095.5	1 070.1	1 101.9	1 197.1
40	1 028.7	1 092.2	1 146.3	1 124.0	1 152.7	1 247.9
42	1 079.5	1 143.0	1 197.1	1 174.8	1 216.2	1 298.7
44	1 130.3	1 193.8	1 247.9	1 228.9	1 267.0	1 365.3
46	1 181.1	1 252.5	1 314.5	1 286.0	1 324.1	1 432.1
48	1 231.9	1 303.3	1 365.3	1 343.2	1 387.6	1 482.9
50	1 282.7	1 354.1	1 416.1	1 400.3	1 444.8	...
52	1 333.5	1 404.9	1 466.9	1 451.1	1 495.6	...
54	1 384.3	1 460.5	1 527.3	1 514.6	1 552.7	...
56	1 435.1	1 511.3	1 590.8	1 565.4	1 603.5	...
58	1 485.9	1 576.3	1 652.5	1 616.2	1 660.7	...
60	1 536.7	1 627.1	1 703.3	1 679.7	1 730.5	...

**GENERAL NOTES:**

- (a) All dimensions are in millimeters.
- (b) The gasket thickness tolerance is +0.8 mm, -0.0 mm.

**NOTES:**

- (1) For gaskets NPS 26 through NPS 60, the outside diameter and inside diameter tolerances are +3.3 mm, -0.0 mm.
- (2) There are no Class 900 flanges NPS 50 and larger.



**Table 24 Abbreviations for Identifying Materials for Jacketed Gaskets**

Material	Abbreviation
<b>Metals</b>	
Aluminum (Al)	AL
Carbon steel (CRS)	CS
Copper (Cu)	CU
Hastelloy B [Ni–Mo (grade B2)]	HAST B
Hastelloy C [Ni–Mo–Cr (grade C-276)]	HAST C
Inconel 600 [Ni–Cr–Fe (grade 600)]	INC 600
Inconel 625 [Ni–Cr–Fe–Cb (grade 625)]	INC 625
Incoloy 800 [Ni–Fe–Cr (grade 800)]	IN 800
Inconel X-750 [Ni–Cr–Fe–Ti (grade X-750)]	INX
Monel [Ni–Cu (grade 400)]	MON
Nickel (Nickel 200)	NI
Soft iron	Soft iron
Stainless steels (Ni–Cr)	3-digit
Tantalum (Ta)	TANT
Titanium (Ti)	TI
<b>Fillers</b>	
Asbestos	ASB
Ceramic	CER
Flexible graphite	F.G.
Polytetrafluoroethylene	PTFE

**Table 25 Example Markings for Jacketed Gaskets**

Description	Marking
NPS 2½, Class 150 ASME B16.5 gasket having a Type 304 metal jacket and a flexible graphite filler material	2½–150–304/F.G. (Manufacturer's trademark) ASME B16.20
NPS 30, Class 300 ASME B16.47 Series B gasket having a carbon-steel jacket and a ceramic filler material	30–300–CS/CER ASME B16.47 B (Manufacturer's trademark) ASME B16.20

# **MANDATORY APPENDIX I**

## **DIMENSIONS OF GASKETS IN U.S. CUSTOMARY UNITS**

This Appendix consists of U.S. Customary versions of metric Tables 3, 5, 7, 9–14, 16, 17, and 21–23.

Table I-1 Type R Ring Gasket Dimensions and Tolerances

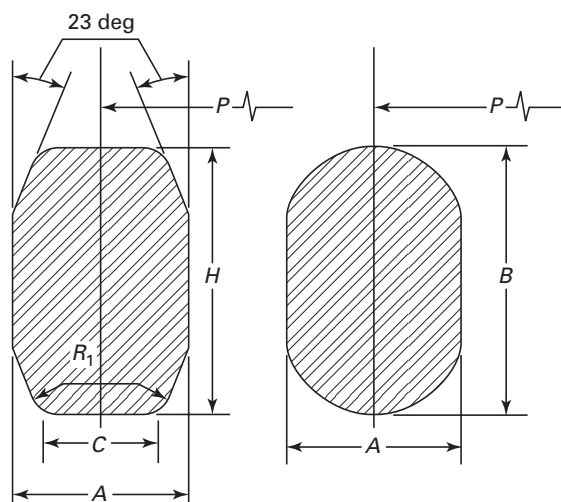

Ring Number	Average Pitch Diameter of Ring, $P$	Width of Ring, $A$	Height of Ring		Width of Flat on Octagonal Ring, $C$	Radius in Octagonal Ring, $R_1$
			Oval, $B$	Octagonal, $H$		
R-11	1.344	0.250	0.44	0.38	0.170	0.06
R-12	1.563	0.313	0.56	0.50	0.206	0.06
R-13	1.688	0.313	0.56	0.50	0.206	0.06
R-14	1.750	0.313	0.56	0.50	0.206	0.06
R-15	1.875	0.313	0.56	0.50	0.206	0.06
R-16	2.000	0.313	0.56	0.50	0.206	0.06
R-17	2.250	0.313	0.56	0.50	0.206	0.06
R-18	2.375	0.313	0.56	0.50	0.206	0.06
R-19	2.563	0.313	0.56	0.50	0.206	0.06
R-20	2.688	0.313	0.56	0.50	0.206	0.06
R-21	2.844	0.438	0.69	0.63	0.305	0.06
R-22	3.250	0.313	0.56	0.50	0.206	0.06
R-23	3.250	0.438	0.69	0.63	0.305	0.06
R-24	3.750	0.438	0.69	0.63	0.305	0.06
R-25	4.000	0.313	0.56	0.50	0.206	0.06
R-26	4.000	0.438	0.69	0.63	0.305	0.06
R-27	4.250	0.438	0.69	0.63	0.305	0.06
R-28	4.375	0.500	0.75	0.69	0.341	0.06
R-29	4.500	0.313	0.56	0.50	0.206	0.06
R-30	4.625	0.438	0.69	0.63	0.305	0.06
R-31	4.875	0.438	0.69	0.63	0.305	0.06
R-32	5.000	0.500	0.75	0.69	0.341	0.06
R-33	5.188	0.313	0.56	0.50	0.206	0.06
R-34	5.188	0.438	0.69	0.63	0.305	0.06
R-35	5.375	0.438	0.69	0.63	0.305	0.06
R-36	5.875	0.313	0.56	0.50	0.206	0.06
R-37	5.875	0.438	0.69	0.63	0.305	0.06
R-38	6.188	0.625	0.88	0.81	0.413	0.06
R-39	6.375	0.438	0.69	0.63	0.305	0.06
R-40	6.750	0.313	0.56	0.50	0.206	0.06

Table I-1 Type R Ring Gasket Dimensions and Tolerances (Cont'd)

Ring Number	Average Pitch Diameter of Ring, <i>P</i>	Width of Ring, <i>A</i>	Height of Ring		Width of Flat on Octagonal Ring, <i>C</i>	Radius in Octagonal Ring, <i>R</i> <sub>1</sub>
			Oval, <i>B</i>	Octagonal, <i>H</i>		
R-41	7.125	0.438	0.69	0.63	0.305	0.06
R-42	7.500	0.750	1.00	0.94	0.485	0.06
R-43	7.625	0.313	0.56	0.50	0.206	0.06
R-44	7.625	0.438	0.69	0.63	0.305	0.06
R-45	8.313	0.438	0.69	0.63	0.305	0.06
R-46	8.313	0.500	0.75	0.69	0.341	0.06
R-47	9.000	0.750	1.00	0.94	0.485	0.06
R-48	9.750	0.313	0.56	0.50	0.206	0.06
R-49	10.625	0.438	0.69	0.63	0.305	0.06
R-50	10.625	0.625	0.88	0.81	0.413	0.06
R-51	11.000	0.875	1.13	1.06	0.583	0.06
R-52	12.000	0.313	0.56	0.50	0.206	0.06
R-53	12.750	0.438	0.69	0.63	0.305	0.06
R-54	12.750	0.625	0.88	0.81	0.413	0.06
R-55	13.500	1.125	1.44	1.38	0.780	0.09
R-56	15.000	0.313	0.56	0.50	0.206	0.06
R-57	15.000	0.438	0.69	0.63	0.305	0.06
R-58	15.000	0.875	1.13	1.06	0.583	0.06
R-59	15.625	0.313	0.56	0.50	0.206	0.06
R-60	16.000	1.250	1.56	1.50	0.879	0.09
R-61	16.500	0.438	0.69	0.63	0.305	0.06
R-62	16.500	0.625	0.88	0.81	0.413	0.06
R-63	16.500	1.000	1.31	1.25	0.681	0.09
R-64	17.875	0.313	0.56	0.50	0.206	0.06
R-65	18.500	0.438	0.69	0.63	0.305	0.06
R-66	18.500	0.625	0.88	0.81	0.413	0.06
R-67	18.500	1.125	1.44	1.38	0.780	0.09
R-68	20.375	0.313	0.56	0.50	0.206	0.06
R-69	21.000	0.438	0.69	0.63	0.305	0.06
R-70	21.000	0.750	1.00	0.94	0.485	0.06
R-71	21.000	1.125	1.44	1.38	0.780	0.09
R-72	22.000	0.313	0.56	0.50	0.206	0.06
R-73	23.000	0.500	0.75	0.69	0.341	0.06
R-74	23.000	0.750	1.00	0.94	0.485	0.06
R-75	23.000	1.250	1.56	1.50	0.879	0.09
R-76	26.500	0.313	0.56	0.50	0.206	0.06
R-77	27.250	0.625	0.88	0.81	0.413	0.06
R-78	27.250	1.000	1.31	1.25	0.681	0.09
R-79	27.250	1.375	1.75	1.63	0.977	0.09
R-80	24.250	0.313	...	0.50	0.206	0.06
R-81	25.000	0.563	...	0.75	0.377	0.06
R-82	2.250	0.438	...	0.63	0.305	0.06
R-84	2.500	0.438	...	0.63	0.305	0.06
R-85	3.125	0.500	...	0.69	0.341	0.06
R-86	3.563	0.625	...	0.81	0.413	0.06
R-87	3.938	0.625	...	0.81	0.413	0.06
R-88	4.875	0.750	...	0.94	0.485	0.06
R-89	4.500	0.750	...	0.94	0.485	0.06
R-90	6.125	0.875	...	1.06	0.583	0.06

Table I-1 Type R Ring Gasket Dimensions and Tolerances (Cont'd)

Ring Number	Average Pitch Diameter of Ring, $P$	Width of Ring, $A$	Height of Ring		Width of Flat on Octagonal Ring, $C$	Radius in Octagonal Ring, $R_1$
			Oval, $B$	Octagonal, $H$		
R-91	10.250	1.250	...	1.50	0.879	0.09
R-92	9.000	0.438	0.69	0.63	0.305	0.06
R-93	29.500	0.750	...	0.94	0.485	0.06
R-94	31.500	0.750	...	0.94	0.485	0.06
R-95	33.750	0.750	...	0.94	0.485	0.06
R-96	36.000	0.875	...	1.06	0.583	0.06
R-97	38.000	0.875	...	1.06	0.583	0.06
R-98	40.250	0.875	...	1.06	0.583	0.06
R-99	9.250	0.438	...	0.63	0.305	0.06
R-100	29.500	1.125	...	1.38	0.780	0.09
R-101	31.500	1.250	...	1.50	0.879	0.09
R-102	33.750	1.250	...	1.50	0.879	0.09
R-103	36.000	1.250	...	1.50	0.879	0.09
R-104	38.000	1.375	...	1.63	0.977	0.09
R-105	40.250	1.375	...	1.63	0.977	0.09

## GENERAL NOTES:

(a) All dimensions are in inches.

(b) Tolerances:

 $P$  = average pitch diameter of ring,  $\pm 0.007$  $A$  = width of ring,  $\pm 0.008$  $B, H$  = height of ring,  $+0.05, -0.02$ 

Variation in height throughout the entire circumference of any given ring shall not exceed 0.02 within these tolerances.

 $C$  = width of flat on octagonal ring,  $\pm 0.008$  $R_1$  = radius in ring,  $\pm 0.02$ 23 deg = angle,  $\pm \frac{1}{2}$  deg

Table I-2 Type RX Ring Gasket Dimensions and Tolerances

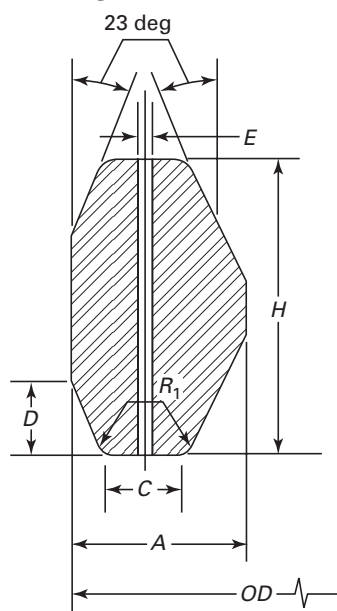

Ring Number	Outside Diameter of Ring, OD	Width of Ring, A	Width of Flat, C	Height of Outside Bevel, D	Height of Ring, H	Radius in Octagonal Ring, R <sub>1</sub>	Hole Size, E [Note (1)]
RX-20	3.000	0.344	0.182	0.125	0.750	0.06	...
RX-23	3.672	0.469	0.254	0.167	1.000	0.06	...
RX-24	4.172	0.469	0.254	0.167	1.000	0.06	...
RX-25	4.313	0.344	0.182	0.125	0.750	0.06	...
RX-26	4.406	0.469	0.254	0.167	1.000	0.06	...
RX-27	4.656	0.469	0.254	0.167	1.000	0.06	...
RX-31	5.297	0.469	0.254	0.167	1.000	0.06	...
RX-35	5.797	0.469	0.254	0.167	1.000	0.06	...
RX-37	6.297	0.469	0.254	0.167	1.000	0.06	...
RX-39	6.797	0.469	0.254	0.167	1.000	0.06	...
RX-41	7.547	0.469	0.254	0.167	1.000	0.06	...
RX-44	8.047	0.469	0.254	0.167	1.000	0.06	...
RX-45	8.734	0.469	0.254	0.167	1.000	0.06	...
RX-46	8.750	0.531	0.263	0.188	1.125	0.06	...
RX-47	9.656	0.781	0.407	0.271	1.625	0.09	...
RX-49	11.047	0.469	0.254	0.167	1.000	0.06	...
RX-50	11.156	0.656	0.335	0.208	1.250	0.06	...
RX-53	13.172	0.469	0.254	0.167	1.000	0.06	...
RX-54	13.281	0.656	0.335	0.208	1.250	0.06	...
RX-57	15.422	0.469	0.254	0.167	1.000	0.06	...
RX-63	17.391	1.063	0.582	0.333	2.000	0.09	...
RX-65	18.922	0.469	0.254	0.167	1.000	0.06	...
RX-66	18.031	0.656	0.335	0.208	1.250	0.06	...
RX-69	21.422	0.469	0.254	0.167	1.000	0.06	...
RX-70	21.656	0.781	0.407	0.271	1.625	0.09	...
RX-73	23.469	0.531	0.263	0.208	1.250	0.06	...
RX-74	23.656	0.781	0.407	0.271	1.625	0.09	...
RX-82	2.672	0.469	0.254	0.167	1.000	0.06	0.06
RX-84	2.922	0.469	0.254	0.167	1.000	0.06	0.06
RX-85	3.547	0.531	0.263	0.167	1.000	0.06	0.06

**Table I-2 Type RX Ring Gasket Dimensions and Tolerances (Cont'd)**

Ring Number	Outside Diameter of Ring, <i>OD</i>	Width of Ring, <i>A</i>	Width of Flat, <i>C</i>	Height of Outside Bevel, <i>D</i>	Height of Ring, <i>H</i>	Radius in Octagonal Ring, <i>R</i> <sub>1</sub>	Hole Size, <i>E</i> [Note (1)]
RX-86	4.078	0.594	0.335	0.188	1.125	0.06	0.09
RX-87	4.453	0.594	0.335	0.188	1.125	0.06	0.09
RX-88	5.484	0.688	0.407	0.208	1.250	0.06	0.12
RX-89	5.109	0.719	0.407	0.208	1.250	0.06	0.12
RX-90	6.875	0.781	0.479	0.292	1.750	0.09	0.12
RX-91	11.297	1.188	0.780	0.297	1.781	0.09	0.12
RX-99	9.672	0.469	0.254	0.167	1.000	0.06	...
RX-201	2.026	0.226	0.126	0.057	0.445	0.02 (3)	...
RX-205	2.453	0.219	0.120	0.072 (2)	0.437	0.02 (3)	...
RX-210	3.844	0.375	0.213	0.125 (2)	0.750	0.03 (3)	...
RX-215	5.547	0.469	0.210	0.167 (2)	1.000	0.06 (3)	...

## GENERAL NOTES:

(a) All dimensions are in inches.

(b) Tolerances:

*OD* = outside diameter of ring, +0.020, -0*A* = width of ring, +0.008, -0

Variation in width throughout the entire circumference of any ring shall not exceed 0.004 within these tolerances.

*C* = width of flat, +0.006, -0*D* = height of outside bevel, +0, -0.030*H* = height of ring, +0.008, -0

Variation in height throughout the entire circumference of any ring shall not exceed 0.004 within these tolerances.

*R*<sub>1</sub> = radius of ring, ±0.02

23 deg = angle, ±½ deg

*E* = hole size, ±0.02

## NOTES:

(1) Rings RX-82 through RX-91 only require one pressure passage hole as illustrated. The centerline of the hole shall be located at the mid-point of dimension *C*.

(2) Tolerance on these dimensions is +0, -0.015.

(3) Tolerance on these dimensions is +0.02, -0.

Table I-3 Type BX Ring Gasket Dimensions and Tolerances

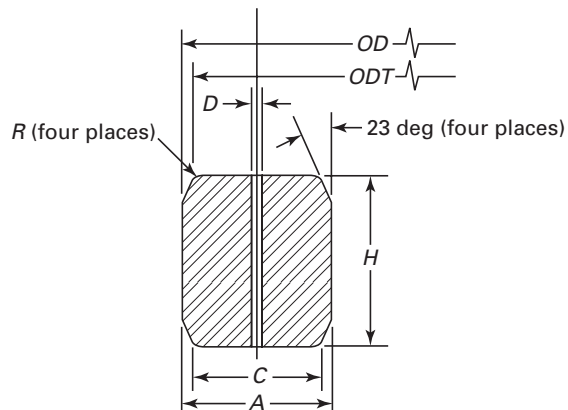

Ring Number	Nominal Size	Outside Diameter of Ring, OD	Height of Ring, H	Width of Ring, A	Outside Diameter of Flat, ODT	Width of Flat, C	Hole Size, D [Note (1)]
BX-150	1 <sup>11</sup> / <sub>16</sub>	2.842	0.366	0.366	2.790	0.314	0.06
BX-151	1 <sup>13</sup> / <sub>16</sub>	3.008	0.379	0.379	2.954	0.325	0.06
BX-152	2 <sup>1</sup> / <sub>16</sub>	3.334	0.403	0.403	3.277	0.346	0.06
BX-153	2 <sup>9</sup> / <sub>16</sub>	3.974	0.448	0.448	3.910	0.385	0.06
BX-154	3 <sup>1</sup> / <sub>16</sub>	4.600	0.488	0.488	4.531	0.419	0.06
BX-155	4 <sup>1</sup> / <sub>16</sub>	5.825	0.560	0.560	5.746	0.481	0.06
BX-156	7 <sup>1</sup> / <sub>16</sub>	9.367	0.733	0.733	9.263	0.629	0.12
BX-157	9	11.593	0.826	0.826	11.476	0.709	0.12
BX-158	11	13.860	0.911	0.911	13.731	0.782	0.12
BX-159	13 <sup>5</sup> / <sub>8</sub>	16.800	1.012	1.012	16.657	0.869	0.12
BX-160	13 <sup>5</sup> / <sub>8</sub>	15.850	0.938	0.541	15.717	0.408	0.12
BX-161	16 <sup>5</sup> / <sub>8</sub>	19.347	1.105	0.638	19.191	0.482	0.12
BX-162	16 <sup>5</sup> / <sub>8</sub>	18.720	0.560	0.560	18.641	0.481	0.06
BX-163	18 <sup>3</sup> / <sub>4</sub>	21.896	1.185	0.684	21.728	0.516	0.12
BX-164	18 <sup>3</sup> / <sub>4</sub>	22.463	1.185	0.968	22.295	0.800	0.12
BX-165	21 <sup>1</sup> / <sub>4</sub>	24.595	1.261	0.728	24.417	0.550	0.12
BX-166	21 <sup>1</sup> / <sub>4</sub>	25.198	1.261	1.029	25.020	0.851	0.12
BX-167	26 <sup>3</sup> / <sub>4</sub>	29.896	1.412	0.516	29.696	0.316	0.06
BX-168	26 <sup>3</sup> / <sub>4</sub>	30.128	1.412	0.632	29.928	0.432	0.06
BX-169	5 <sup>1</sup> / <sub>8</sub>	6.831	0.624	0.509	6.743	0.421	0.06
BX-170	6 <sup>5</sup> / <sub>8</sub>	8.584	0.560	0.560	8.505	0.481	0.06
BX-171	8 <sup>9</sup> / <sub>16</sub>	10.529	0.560	0.560	10.450	0.481	0.06
BX-172	11 <sup>5</sup> / <sub>32</sub>	13.113	0.560	0.560	13.034	0.481	0.06
BX-303	30	33.573	1.494	0.668	33.361	0.457	0.06

## GENERAL NOTES:

(a) All dimensions are in inches.

(b) Radius,  $R$ , shall be 8% to 12% of the gasket height,  $H$ .

(c) Tolerances:

 $OD$  = outside diameter of ring, +0, -0.005 $H$  = height of ring, +0.008, -0

Variation in height throughout the entire circumference of any ring shall not exceed 0.004 within these tolerances.

 $A$  = width of ring, +0.008, -0

Variation in width throughout the entire circumference of any ring shall not exceed 0.004 within these tolerances.

 $ODT$  = outside diameter of flat,  $\pm 0.002$  $C$  = width of flat, +0.006, -0 $D$  = hole size,  $\pm 0.02$  $R$  = radius of ring [see General Note (b)]23 deg = angle,  $\pm 1/4$  deg

## NOTE:

(1) One pressure passage hole is required per gasket as illustrated. The centerline of the hole shall be located at the midpoint of dimension  $C$ .



Table I-4 Dimensions for Spiral-Wound Gaskets Used With ASME B16.5 Flanges

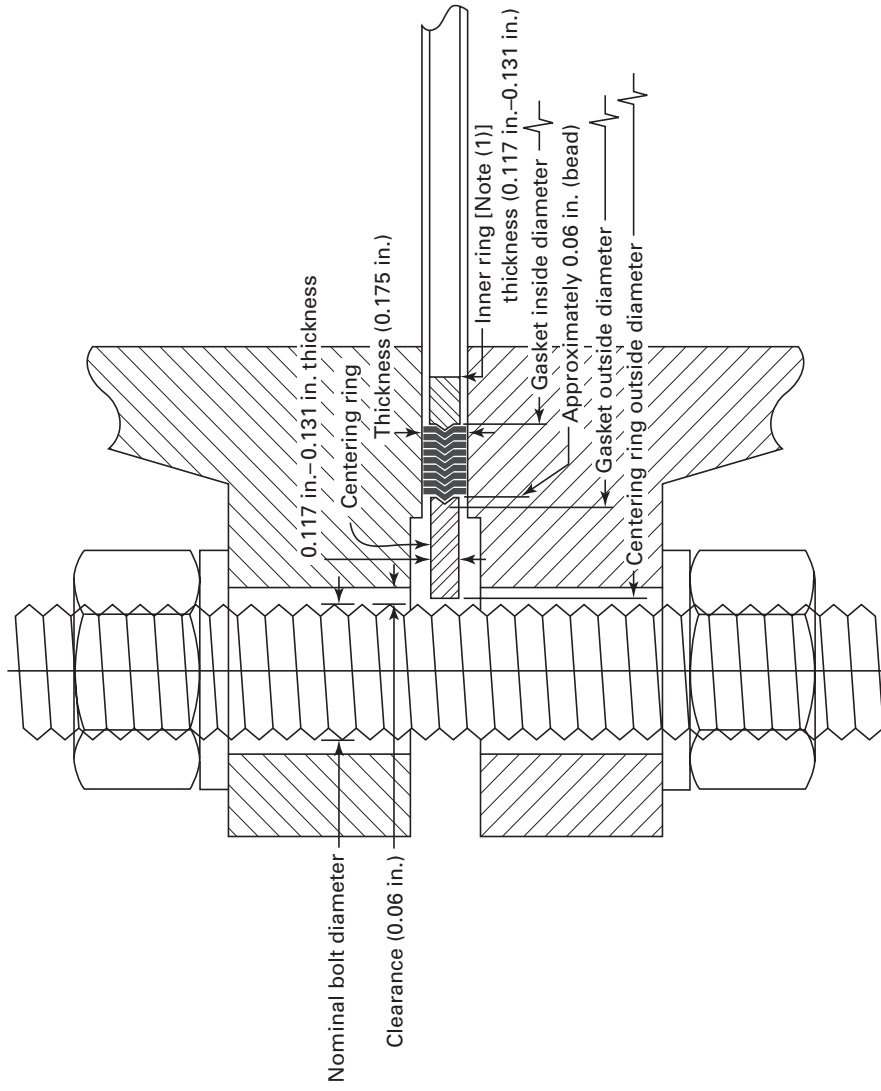

**Table I-4 Dimensions for Spiral-Wound Gaskets Used With ASME B16.5 Flanges (Cont'd)**

Flange Size (NPS)	Outside Diameter of Gasket [Note (1)]		Inside Diameter of Gasket by Class [Notes (2), (3)]										Outside Diameter of Centering Ring by Class [Note (4)]																								
	Classes		150					300					450					600					900					1500					2500				
	150, 300, 400, 600	900, 1500, 2500	150	300	400 (5)	600	900 (5)	1500	2500 (5)	150	300	400 (5)	600	900 (5)	1500	2500 (5)	150	300	400 (5)	600	900 (5)	1500	2500 (5)	150	300	400 (5)	600	900 (5)	1500	2500 (5)							
1/2	1.25	1.25	0.75	0.75	...	0.75	...	0.75	0.75	...	0.75	...	0.75	...	0.75	0.75	1.88	2.13	...	2.13	...	2.13	...	2.13	...	2.13	...	2.13	...	2.50	2.75						
3/4	1.56	1.56	1.00	1.00	...	1.00	...	1.00	1.00	...	1.00	...	1.00	...	1.00	1.00	2.25	2.63	...	2.63	...	2.63	...	2.63	...	2.63	...	2.63	...	2.75	3.00						
1	1.88	1.88	1.25	1.25	...	1.25	...	1.25	1.25	...	1.25	...	1.25	...	1.25	1.25	2.63	2.88	...	2.88	...	2.88	...	2.88	...	2.88	...	2.88	...	3.13	3.38						
1 1/4	2.38	2.38	1.88	1.88	...	1.88	...	1.88	1.88	...	1.88	...	1.88	...	1.88	1.88	3.00	3.25	...	3.25	...	3.25	...	3.25	...	3.25	...	3.25	...	3.50	4.13						
1 1/2	2.75	2.75	2.13	2.13	...	2.13	...	2.13	2.13	...	2.13	...	2.13	...	2.13	1.88	3.38	3.75	...	3.75	...	3.75	...	3.75	...	3.75	...	3.75	...	3.88	4.63						
2	3.38	3.38	2.75	2.75	...	2.75	...	2.75	2.75	...	2.75	...	2.75	...	2.75	2.31	4.13	4.38	...	4.38	...	4.38	...	4.38	...	4.38	...	4.38	...	5.63	5.75						
2 1/2	3.88	3.88	3.25	3.25	...	3.25	...	3.25	3.25	...	3.25	...	3.25	...	3.25	2.75	4.88	5.13	...	5.13	...	5.13	...	5.13	...	5.13	...	5.13	...	6.50	6.63						
3	4.75	4.75	4.00	4.00	...	4.00	...	4.00	3.75	...	3.75	...	3.75	...	3.63	5.38	5.88	...	5.88	...	5.88	...	5.88	...	5.88	...	5.88	...	6.88	7.75							
4	5.88	5.88	5.00	5.00	...	4.75	...	4.75	4.75	...	4.63	...	4.63	...	4.63	6.88	7.13	7.00	...	7.00	...	7.00	...	7.00	...	7.00	...	8.13	8.25	9.25							
5	7.00	7.00	6.13	6.13	...	5.81	...	5.81	5.81	...	5.63	...	5.63	...	5.63	7.75	8.50	8.38	...	8.38	...	8.38	...	8.38	...	8.38	...	9.75	10.00	11.00							
6	8.25	8.25	7.19	7.19	...	6.88	...	6.88	6.88	...	6.75	...	6.75	...	6.75	8.75	9.88	9.75	...	9.75	...	9.75	...	9.75	...	9.75	...	11.38	11.13	12.50							
8	10.38	10.13	9.19	9.19	...	8.88	...	8.88	8.75	...	8.50	...	8.50	...	8.50	11.00	12.13	12.00	...	12.00	...	12.00	...	12.00	...	12.00	...	14.13	13.88	15.25							
10	12.50	12.25	11.31	11.31	...	10.81	...	10.81	10.88	...	10.50	...	10.50	...	10.63	13.38	14.25	14.13	...	14.13	...	14.13	...	14.13	...	14.13	...	17.13	17.13	18.75							
12	14.75	14.50	13.38	13.38	...	12.88	...	12.88	12.75	...	12.50	...	12.50	...	12.50	16.13	16.63	16.50	...	16.50	...	16.50	...	16.50	...	16.50	...	19.63	20.50	21.63							
14	16.00	15.75	14.63	14.63	...	14.25	...	14.25	14.00	...	14.25	...	14.25	...	...	17.75	19.13	19.00	...	19.00	...	19.00	...	19.00	...	19.38	20.50	22.75	...								
16	18.25	18.00	16.63	16.63	...	16.25	...	16.25	16.25	...	16.00	...	16.00	...	...	20.25	21.25	21.13	...	21.13	...	21.13	...	21.13	...	21.13	...	22.63	25.25	...							
18	20.75	20.50	18.69	18.69	...	18.50	...	18.50	18.25	...	18.25	...	18.25	...	...	21.63	23.50	23.38	...	23.38	...	23.38	...	23.38	...	23.38	...	25.13	27.75	...							
20	22.75	22.50	20.69	20.69	...	20.50	...	20.50	20.50	...	20.50	...	20.50	...	...	23.88	25.75	25.50	...	25.50	...	25.50	...	25.50	...	25.50	...	27.50	29.75	...							
24	27.00	26.75	24.75	24.75	...	24.75	...	24.75	24.75	...	24.75	...	24.75	...	...	28.25	30.50	30.50	...	30.50	...	30.50	...	30.50	...	30.50	...	33.00	35.50	...							

**GENERAL NOTES:**

- (a) All dimensions are in inches.
  - (b) For reference, see Table I-4 illustration on previous page.
  - (c) The gasket thickness tolerance is ±0.005 in. measured across the metallic portion of the gasket, not including the filler, which may protrude slightly beyond the metal.
  - (d) For limitations on the maximum flange bore for use with these spiral-wound gaskets, see Table I-10.
- NOTES:**
- (1) The gasket outside diameter tolerance for NPS 1/2 through NPS 8 is ±0.03 in.; for NPS 10 through NPS 24, +0.06 in., -0.03 in.
  - (2) Refer to para. 3.2.5 for required use of inner rings.
  - (3) The gasket inside diameter tolerance for NPS 1/2 through NPS 8 is ±0.016 in.; for NPS 10 through NPS 24, ±0.03 in.
  - (4) The centering ring outside diameter tolerance is ±0.03 in.
  - (5) There are no Class 400 flanges in NPS 1/2 through NPS 3 (use Class 600), Class 900 flanges in NPS 1/2 through NPS 2 1/2 (use Class 1500), or Class 2500 flanges NPS 14 and larger.

Table I-5 Dimensions for Spiral-Wound Gaskets Used With ASME B16.47 Series A Flanges

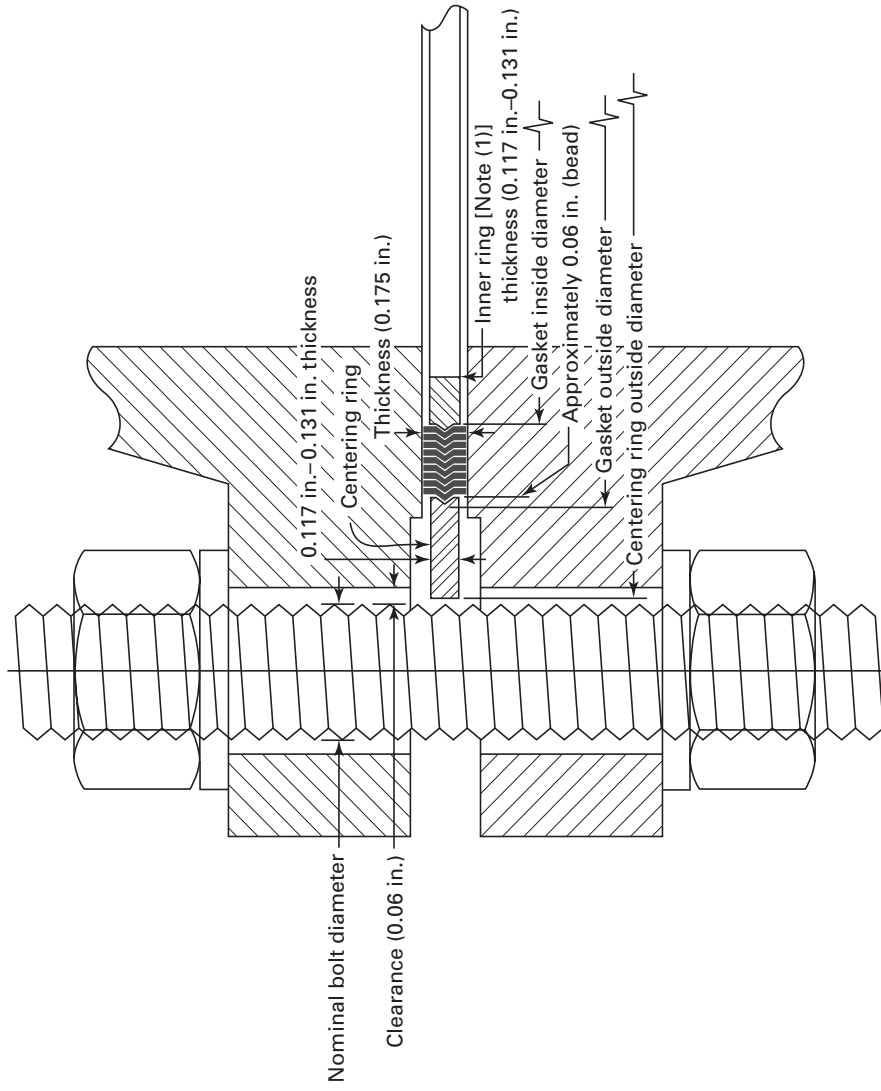

Table I-5 Dimensions for Spiral-Wound Gaskets Used With ASME B16.47 Series A Flanges (Cont'd)

Flange Size (NPS)	Class 150				Class 300				Class 400				Class 600				Class 900				
	Gasket		Centering Ring		Gasket		Centering Ring		Gasket		Centering Ring		Gasket		Centering Ring		Gasket		Centering Ring		
	Inside Diameter [Notes (1), (2)]	Outside Diameter [Note (3)]	Outside Diameter [Note (4)]	Inside Diameter [Notes (1), (2)]	Outside Diameter [Note (3)]	Outside Diameter [Note (4)]	Inside Diameter [Notes (1), (2)]	Outside Diameter [Note (3)]	Outside Diameter [Note (4)]	Inside Diameter [Notes (1), (2)]	Outside Diameter [Note (3)]	Outside Diameter [Note (4)]	Inside Diameter [Notes (1), (2)]	Outside Diameter [Note (3)]	Outside Diameter [Note (4)]	Inside Diameter [Notes (1), (2)]	Outside Diameter [Note (3)]	Outside Diameter [Note (4)]	Inside Diameter [Notes (1), (2)]	Outside Diameter [Notes (3), (4), (5)]	
26	26.50	27.75	30.50	27.00	29.00	32.88	27.00	29.00	32.75	27.00	29.00	34.13	27.00	29.00	34.75	27.00	29.00	34.13	27.00	29.00	34.75
28	28.50	29.75	32.75	29.00	31.00	35.38	29.00	31.00	35.13	29.00	31.00	36.00	29.00	31.00	37.25	29.00	31.00	36.00	29.00	31.00	37.25
30	30.50	31.75	34.75	31.25	33.25	37.50	31.25	33.25	37.25	31.25	33.25	38.25	31.25	33.25	39.75	31.25	33.25	38.25	31.25	33.25	39.75
32	32.50	33.88	37.00	33.50	35.50	39.63	33.50	35.50	39.50	33.50	35.50	40.25	33.50	35.50	42.25	33.50	35.50	40.25	33.50	35.50	42.25
34	34.50	35.88	39.00	35.50	37.50	41.63	35.50	37.50	41.50	35.50	37.50	42.25	35.50	37.50	44.75	35.50	37.50	42.25	35.50	37.50	44.75
36	36.50	38.13	41.25	37.63	39.63	44.00	37.63	39.63	44.00	37.63	39.63	44.50	37.63	39.63	47.25	37.63	39.63	44.50	37.63	39.63	47.25
38	38.50	40.13	43.75	38.50	40.00	41.50	38.50	40.25	42.25	38.25	40.25	43.50	39.00	41.00	47.25	39.00	41.00	43.50	40.75	42.75	47.25
40	40.50	42.13	45.75	40.25	42.13	43.88	40.38	42.38	44.38	40.38	42.38	45.50	41.25	43.25	49.25	41.25	43.25	45.50	43.25	45.25	49.25
42	42.50	44.25	48.00	42.25	44.13	45.88	42.38	44.38	46.38	42.38	44.38	48.00	43.50	45.50	52.25	43.50	45.50	48.00	45.25	47.25	52.25
44	44.50	46.38	50.25	44.50	46.50	48.00	44.50	46.50	48.50	44.50	46.50	50.00	45.75	47.75	55.25	45.75	47.75	50.00	47.50	49.50	55.25
46	46.50	48.38	52.25	46.38	48.38	50.13	47.00	49.00	50.75	47.75	49.75	52.25	47.75	49.75	57.25	47.75	49.75	52.25	50.00	52.00	57.25
48	48.50	50.38	54.50	48.63	50.63	52.13	49.00	51.00	53.00	50.00	52.00	54.75	50.00	52.00	60.25	50.00	52.00	54.75	52.00	54.00	60.25
50	50.50	52.50	56.50	51.00	53.00	54.25	51.00	53.00	55.25	52.00	54.00	57.00	52.00	54.00	62.25	52.00	54.00	57.00	54.00	56.00	62.25
52	52.50	54.50	58.75	53.00	55.00	56.25	53.00	55.00	57.25	54.00	56.00	59.00	54.00	56.00	64.25	54.00	56.00	59.00	56.00	58.00	64.25
54	54.50	56.50	61.00	55.25	57.25	58.75	55.25	57.25	59.75	56.25	58.25	61.25	56.25	58.25	66.25	56.25	58.25	61.25	58.25	60.25	66.25
56	56.50	58.50	63.25	57.25	59.25	60.75	57.25	59.25	61.75	58.25	60.25	63.50	58.25	60.25	68.25	58.25	60.25	63.50	60.25	62.50	68.25
58	58.50	60.50	65.50	59.50	61.50	62.75	59.25	61.25	63.75	60.50	62.50	65.50	60.50	62.50	70.25	60.50	62.50	65.50	62.50	64.50	70.25
60	60.50	62.50	67.50	61.50	63.50	64.75	61.75	63.75	66.25	62.75	64.75	68.25	62.75	64.75	72.25	62.75	64.75	68.25	64.75	66.75	72.25

GENERAL NOTES:

- (a) All dimensions are in inches.
- (b) For reference, see Table I-5 illustration on previous page.
- (c) The gasket thickness tolerance is  $\pm 0.005$  in. measured across the metallic portion of the gasket, not including the filler, which may protrude slightly beyond the metal.
- (d) For limitations on the maximum flange bore for use with these spiral-wound gaskets, see Table I-11.
- (e) ASME B16.47 Series A flanges NPS 12 through NPS 24 have the same raised face dimensions as ASME B16.5 flanges.

NOTES:

- (1) Refer to para. 3.2.5 for required use of inner rings.
- (2) The gasket inside diameter tolerance for NPS 26 through NPS 34 is  $\pm 0.03$  in., and the tolerance for NPS 36 through NPS 60 is  $\pm 0.05$  in.
- (3) The gasket outside diameter tolerance for NPS 26 through NPS 60 is  $\pm 0.06$  in.
- (4) The centering ring outside diameter tolerance is  $\pm 0.03$  in.
- (5) There are no Class 900 flanges NPS 50 and larger.

Table I-6 Dimensions for Spiral-Wound Gaskets Used With ASME B16.47 Series B Flanges

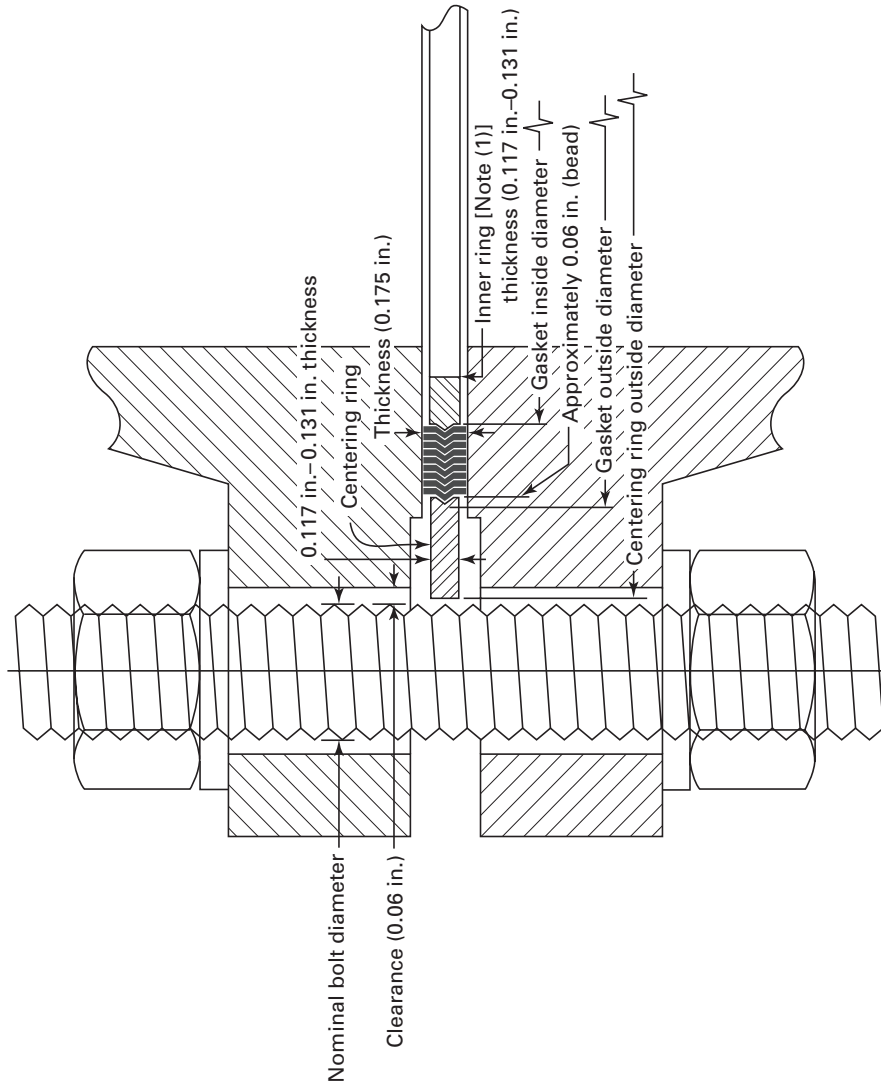

**Table I-6 Dimensions for Spiral-Wound Gaskets Used With ASME B16.47 Series B Flanges (Cont'd)**

Flange Size (NPS)	Class 150				Class 300				Class 400				Class 600				Class 900			
	Gasket		Centering Ring		Gasket		Centering Ring		Gasket		Centering Ring		Gasket		Centering Ring		Gasket		Centering Ring	
	Inside Diameter [Notes (1), (2)]	Outside Diameter [Note (3)]	Inside Diameter [Notes (1), (2)]	Outside Diameter [Note (4)]	Inside Diameter [Notes (1), (2)]	Outside Diameter [Note (3)]	Inside Diameter [Notes (1), (2)]	Outside Diameter [Note (4)]	Inside Diameter [Notes (1), (2)]	Outside Diameter [Note (3)]	Inside Diameter [Notes (1), (2)]	Outside Diameter [Note (4)]	Inside Diameter [Notes (1), (2)]	Outside Diameter [Note (3)]	Inside Diameter [Notes (1), (2)]	Outside Diameter [Note (4)]	Inside Diameter [Notes (1), (2)]	Outside Diameter [Note (3)]	Inside Diameter [Notes (1), (2)]	Outside Diameter [Notes (3), (4), (5)]
26	26.50	27.50	26.50	28.56	26.50	28.00	30.38	26.25	27.50	29.38	26.13	28.13	26.13	28.13	30.13	27.25	29.50	27.25	29.50	33.00
28	28.50	29.50	28.50	30.56	28.50	30.00	32.50	28.13	29.50	31.50	27.75	29.75	27.75	29.75	32.25	29.25	31.50	29.25	31.50	35.50
30	30.50	31.50	30.50	32.56	30.50	32.00	34.88	30.13	31.75	33.75	30.63	32.63	30.63	32.63	34.63	31.75	33.75	31.75	33.75	37.75
32	32.50	33.50	32.50	34.69	32.50	34.00	37.00	32.00	33.88	35.88	32.75	34.75	32.75	34.75	36.75	34.00	36.00	34.00	36.00	40.00
34	34.50	35.75	34.50	36.81	34.50	36.00	39.13	34.13	35.88	37.88	35.00	37.00	35.00	37.00	39.25	36.25	38.25	36.25	38.25	42.25
36	36.50	37.75	36.50	38.88	36.50	38.00	41.25	36.13	38.00	40.25	37.00	39.00	37.00	39.00	41.25	37.25	39.25	37.25	39.25	44.25
38	38.37	39.75	39.75	41.13	39.75	41.25	43.25	38.25	40.25	42.25	39.00	41.00	39.00	41.00	43.50	40.75	42.75	40.75	42.75	47.25
40	40.25	41.88	41.75	43.13	41.75	43.25	45.25	40.38	42.38	44.38	41.25	43.25	41.25	43.25	45.50	43.25	45.25	43.25	45.25	49.25
42	42.50	43.88	43.75	45.13	43.75	45.25	47.25	42.38	44.38	46.38	43.50	45.50	43.50	45.50	48.00	45.25	47.25	45.25	47.25	51.25
44	44.25	45.88	45.75	47.13	45.75	47.25	49.25	44.50	46.50	48.50	45.75	47.75	45.75	47.75	50.00	47.50	49.50	47.50	49.50	53.88
46	46.50	48.19	47.88	49.44	47.88	49.38	51.88	47.00	49.00	50.75	47.75	49.75	47.75	49.75	52.25	50.00	52.00	50.00	52.00	56.50
48	48.50	50.00	49.75	51.44	49.75	51.63	53.88	49.00	51.00	53.00	50.00	52.00	50.00	52.00	54.75	52.00	54.00	52.00	54.00	58.50
50	50.50	52.19	51.88	53.44	51.88	53.38	55.88	51.00	53.00	55.25	52.00	54.00	52.00	54.00	57.00	54.00	56.00	54.00	56.00	60.00
52	52.50	54.19	53.88	55.44	53.88	55.38	57.88	53.00	55.00	57.25	54.00	56.00	54.00	56.00	59.00	56.00	58.00	56.00	58.00	62.00
54	54.50	56.00	55.25	57.63	55.25	57.25	60.25	55.25	57.25	59.75	56.25	58.25	56.25	58.25	61.25	58.25	60.25	58.25	60.25	64.00
56	56.88	58.18	58.25	59.63	58.25	60.00	62.75	57.25	59.25	61.75	58.25	60.25	58.25	60.25	63.50	60.25	62.50	60.25	62.50	66.00
58	59.07	60.19	60.44	62.19	60.44	61.94	65.19	59.25	61.25	63.75	60.50	62.50	60.50	62.50	65.50	62.50	64.50	62.50	64.50	68.00
60	61.31	62.44	62.56	64.19	62.56	64.19	67.19	61.75	63.75	66.25	62.75	64.75	62.75	64.75	68.25	64.75	66.75	64.75	66.75	70.00

GENERAL NOTES:

- (a) All dimensions are in inches.
- (b) For reference, see Table I-6 illustration on previous page.
- (c) The gasket thickness tolerance is  $\pm 0.005$  in. measured across the metallic portion of the gasket, not including the filler, which may protrude slightly beyond the metal.
- (d) For limitations on the maximum flange bore for use with these spiral-wound gaskets, see Table 18.

NOTES:

- (1) Refer to para. 3.2.5 for required use of inner rings.
- (2) The gasket inside diameter tolerance for NPS 26 through NPS 34 is  $\pm 0.03$  in., and the tolerance for NPS 36 through NPS 60 is  $\pm 0.05$  in.
- (3) The gasket outside diameter tolerance for NPS 26 through NPS 60 is  $\pm 0.06$  in.
- (4) The centering ring outside diameter tolerance is  $\pm 0.03$  in.
- (5) There are no Class 900 flanges NPS 50 and larger.

**Table I-7 Inner-Ring Inside Diameters for Spiral-Wound Gaskets for Use With ASME B16.5 Flanges**

Flange Size (NPS)	Pressure Class						
	150	300	400 [Note (1)]	600	900 [Note (1)]	1500	2500 [Note (1)]
1/2	0.56	0.56	...	0.56	...	0.56	0.56
3/4	0.81	0.81	...	0.81	...	0.81	0.81
1	1.06	1.06	...	1.06	...	1.06	1.06
1 1/4	1.50	1.50	...	1.50	...	1.31	1.31
1 1/2	1.75	1.75	...	1.75	...	1.63	1.63
2	2.19	2.19	...	2.19	...	2.06	2.06
2 1/2	2.62	2.62	...	2.62	...	2.50	2.50
3	3.19	3.19	...	3.19	3.10	3.10	3.10
4	4.19	4.19	4.04	4.04	4.04	3.85	3.85
5	5.19	5.19	5.05	5.05	5.05	4.90	4.90
6	6.19	6.19	6.10	6.10	6.10	5.80	5.80
8	8.50	8.50	8.10	8.10	7.75	7.75	7.75
10	10.56	10.56	10.05	10.05	9.69	9.69	9.69
12	12.50	12.50	12.10	12.10	11.50	11.50	11.50
14	13.75	13.75	13.50	13.50	12.63	12.63	...
16	15.75	15.75	15.35	15.35	14.75	14.50	...
18	17.69	17.69	17.25	17.25	16.75	16.75	...
20	19.69	19.69	19.25	19.25	19.00	18.75	...
24	23.75	23.75	23.25	23.25	23.25	22.75	...

## GENERAL NOTES:

- (a) All dimensions are in inches.  
 (b) The inner-ring thickness shall be 0.117 in. to 0.131 in.  
 (c) For sizes NPS 1/2 through NPS 3, the inside diameter tolerance is  $\pm 0.03$  in.; for larger sizes the inside diameter tolerance is  $\pm 0.06$  in. See Table 15 for minimum pipe wall thicknesses that are suitable for use with standard inner rings.  
 (d) Refer to para. 3.2.5 for required use of inner rings.

## NOTE:

- (1) There are no NPS 1/2 through NPS 3 Class 400 flanges (use Class 600), NPS 1/2 through NPS 2 1/2 Class 900 flanges (use Class 1500), or NPS 14 and larger Class 2500 flanges.

**Table I-8 Inner-Ring Inside Diameters for Spiral-Wound Gaskets Used Between ASME B16.47 Series A Flanges**

Flange Size (NPS)	Pressure Class				
	150	300	400	600	900 [Note (1)]
26	25.75	25.75	26.00	25.50	26.00
28	27.75	27.75	28.00	27.50	28.00
30	29.75	29.75	29.75	29.75	30.25
32	31.75	31.75	32.00	32.00	32.00
34	33.75	33.75	34.00	34.00	34.00
36	35.75	35.75	36.13	36.13	36.25
38	37.75	37.50	37.50	37.50	39.75
40	39.75	39.50	39.38	39.75	41.75
42	41.75	41.50	41.38	42.00	43.75
44	43.75	43.50	43.50	43.75	45.50
46	45.75	45.38	46.00	45.75	48.00
48	47.75	47.63	47.50	48.00	50.00
50	49.75	49.00	49.50	50.00	...
52	51.75	52.00	51.50	52.00	...
54	53.50	53.25	53.25	54.25	...
56	55.50	55.25	55.25	56.25	...
58	57.50	57.00	57.25	58.00	...
60	59.50	60.00	59.75	60.25	...

## GENERAL NOTES:

- (a) All dimensions are in inches.
- (b) The inner-ring thickness shall be 0.117 in. to 0.131 in.
- (c) The inside diameter tolerance is  $\pm 0.12$  in.
- (d) These inner rings are suitable for use with pipe walls 0.38 in. or thicker.
- (e) Refer to para. 3.2.5 for required use of inner rings.

## NOTE:

- (1) There are no Class 900 flanges NPS 50 and larger.



**Table I-9 Inner-Ring Inside Diameters for Spiral-Wound Gaskets Used Between ASME B16.47 Series B Flanges**

Flange Size (NPS)	Pressure Class				
	150	300	400	600	900 [Note (1)]
26	25.75	25.75	25.75	25.38	26.25
28	27.75	27.75	27.63	27.00	28.25
30	29.75	29.75	29.63	29.63	30.75
32	31.75	31.75	31.50	31.25	33.00
34	33.75	33.75	33.50	33.50	35.25
36	35.75	35.75	35.38	35.50	36.25
38	37.75	38.25	37.50	37.50	39.75
40	39.75	40.25	39.38	39.75	41.75
42	41.75	42.75	41.38	42.00	43.75
44	43.75	44.25	43.50	43.75	45.50
46	45.75	46.38	46.00	45.75	48.00
48	47.75	48.50	47.50	48.00	50.00
50	49.75	49.88	49.50	50.00	...
52	51.75	51.88	51.50	52.00	...
54	53.75	53.75	53.25	54.25	...
56	56.00	56.25	55.25	56.25	...
58	58.19	58.44	57.25	58.00	...
60	60.44	61.31	59.75	60.25	...

## GENERAL NOTES:

- (a) All dimensions are in inches.
- (b) The inner-ring thickness shall be 0.117 in. to 0.131 in.
- (c) The inside diameter tolerance is  $\pm 0.12$  in.
- (d) These inner rings are suitable for use with pipe walls 0.375 in. or thicker.
- (e) Refer to para. 3.2.5 for required use of inner rings.

## NOTE:

- (1) There are no Class 900 flanges NPS 50 and larger.

**Table I-10 Maximum Bore of ASME B16.5 Flanges for Use With Spiral-Wound Gaskets**

Flange Size (NPS)	Pressure Class							
	75	150	300	400	600	900 (1)	1500 (1)	2500 (1)
1/2	No flanges	WN flange only (2)	SO flange (3) WN flange (2)	No flanges Use Class 600	WN flange only (2)	No flanges Use Class 1500	WN flange only (2)	
3/4								
1								
1 1/4								
1 1/2		SO flange (3) WN flange (2)			SO flange (3) WN flange (2)			
2		SO flange (3) WN flange, any bore			SO flange (3) WN flange, any bore			
2 1/2					SO flange (3) WN flange, any bore			
3								
4								
6					WN flange with Schedule 10S bore described in ASME B36.19M [includes nozzle (4) but excludes SO flange]			WN flange with SW bore [includes nozzle (4) but excludes SO flange]
8								
10			SO flange WN flange, any bore					
12								
14								
16					WN flange with Schedule 10S bore described in ASME B36.19M [excludes nozzle (4) and SO flange] (5)			
18								
20								
24								

**GENERAL NOTES:**

- (a) This Table shows the maximum bore of flanges for which the spiral-wound gasket dimensions shown in Table I-4 are recommended, considering the tolerances involved, possible eccentric installation, and the possibility that the gasket may extend into the assembled flange bore.
- (b) For maximum permissible flange bores for nonmandatory inner rings, see Table 15.
- (c) Abbreviations: SO = slip on and threaded, WN = welding neck, and SW = standard wall.

**NOTES:**

- (1) Refer to para. 3.2.5 for required use of inner rings. These inner rings may extend into the pipe bore a maximum of 0.06 in. under the worst combination of maximum bore, eccentric installation, and additive tolerances.
- (2) In these sizes, the gasket is suitable for a welding neck flange with a standard wall bore, if the gasket and the flanges are assembled concentrically. This also applies to a nozzle. It is the user's responsibility to determine if the gasket is satisfactory for a flange of any larger bore.
- (3) Gaskets in these sizes are suitable for slip-on flanges only if the gaskets and flanges are assembled concentrically.
- (4) A *nozzle* is a long welding neck; the bore equals the flange NPS.
- (5) An NPS 24 gasket is suitable for nozzles.

**Table I-11 Maximum Bore of ASME B16.47 Series A Flanges for Use With Spiral-Wound Gaskets**

Flange Size (NPS)	Pressure Class				
	150	300	400	600	900
26	(1)	(2)	(2)	(2)	(2)
28	(1)	(2)	(2)	(2)	(2)
30	(1)	(2)	(2)	(2)	(2)
32	(1)	(2)	(2)	(2)	(2)
34	(1)	(2)	(2)	(2)	(2)
36	(1)	(2)	(2)	(2)	(2)
38	(1)	(2)	(2)	(2)	(2)
40	(1)	(2)	(2)	(2)	(2)
42	(1)	(2)	(2)	(2)	(2)
44	(1)	(2)	(2)	(2)	(2)
46	(1)	(2)	(2)	(2)	(2)
48	(1)	(2)	(2)	(2)	(2)
50	(1)	(2)	(2)	(2)	(3)
52	(1)	(2)	(2)	(2)	(3)
56	(1)	(2)	(2)	(2)	(3)
58	(1)	(2)	(2)	(2)	(3)
60	(1)	(2)	(2)	(2)	(3)

## GENERAL NOTES:

- (a) This Table shows the maximum bore of flanges for which the spiral-wound gasket dimensions shown in Table I-5 are recommended, considering the tolerances involved, the possibility of eccentric installation, and the possibility that the gasket may extend into the assembled flange bore.
- (b) Refer to para. 3.2.5 for required use of inner rings.

## NOTES:

- (1) Applies only to welding neck flanges with a bore not larger than the inside diameter of a 0.187-in. wall pipe. Larger bores must be checked individually.
- (2) Applies only to welding neck flanges with a bore not larger than the inside diameter of a 0.25-in. wall pipe, except that NPS 38, Class 300, is not suitable for a bore larger than the inside diameter of a 0.30-in. wall pipe. Larger bores must be checked individually.
- (3) There are no Class 900 flanges NPS 50 and larger.

**Table I-12 Jacketed Gasket Dimensions for ASME B16.5 Flanges**

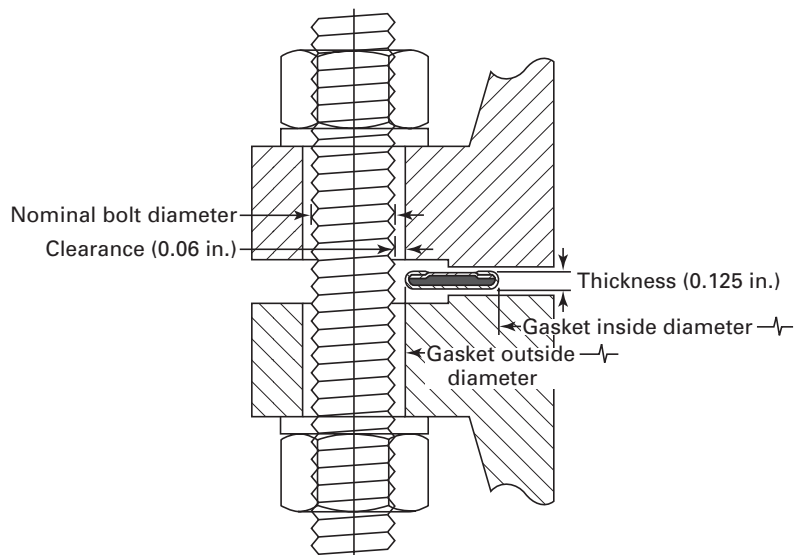

Flange Size (NPS)	Gasket Inside Diameter [Note (1)]	Gasket Outside Diameter by Class [Note (1)]						
		150	300	400 [Note (2)]	600	900 [Note (2)]	1500	2500 [Note (2)]
1/2	0.88	1.75	2.00	...	2.00	...	2.38	2.63
3/4	1.13	2.13	2.50	...	2.50	...	2.63	2.88
1	1.50	2.50	2.75	...	2.75	...	3.00	3.25
1 1/4	1.88	2.88	3.13	...	3.13	...	3.38	4.00
1 1/2	2.13	3.25	3.63	...	3.63	...	3.75	4.50
2	2.88	4.00	4.25	...	4.25	...	5.50	5.63
2 1/2	3.38	4.75	5.00	...	5.00	...	6.38	6.50
3	4.25	5.25	5.75	...	5.75	6.50	6.75	7.63
4	5.19	6.75	7.00	6.88	7.50	8.00	8.13	9.13
5	6.00	7.63	8.38	8.25	9.38	9.63	9.88	10.88
6	7.50	8.63	9.75	9.63	10.38	11.25	11.00	12.38
8	9.38	10.88	12.00	11.88	12.50	14.00	13.75	15.13
10	11.25	13.25	14.13	14.00	15.63	17.00	17.00	18.63
12	13.50	16.00	16.50	16.38	17.88	19.50	20.38	21.50
14	14.75	17.63	19.00	18.88	19.25	20.38	22.63	...
16	16.75	20.13	21.13	21.00	22.13	22.50	25.13	...
18	19.25	21.50	23.38	23.25	24.00	25.00	27.63	...
20	21.00	23.75	25.63	25.38	26.75	27.38	29.63	...
24	25.25	28.13	30.38	30.13	31.00	32.88	35.38	...

GENERAL NOTES:

- (a) All dimensions are in inches.
- (b) The gasket thickness tolerance is +0.03 in., -0.000 in.

NOTES:

- (1) For gaskets NPS 1/2 through NPS 24, the outside and inside diameter tolerances are +0.06 in., -0.000 in.
- (2) There are no Class 400 flanges NPS 1/2 through NPS 3 (use Class 600), Class 900 flanges NPS 1/2 through NPS 2 1/2 (use Class 1500), or Class 2500 flanges NPS 14 and larger.

**Table I-13 Jacketed Gasket Dimensions for  
ASME B16.47 Series A Flanges**

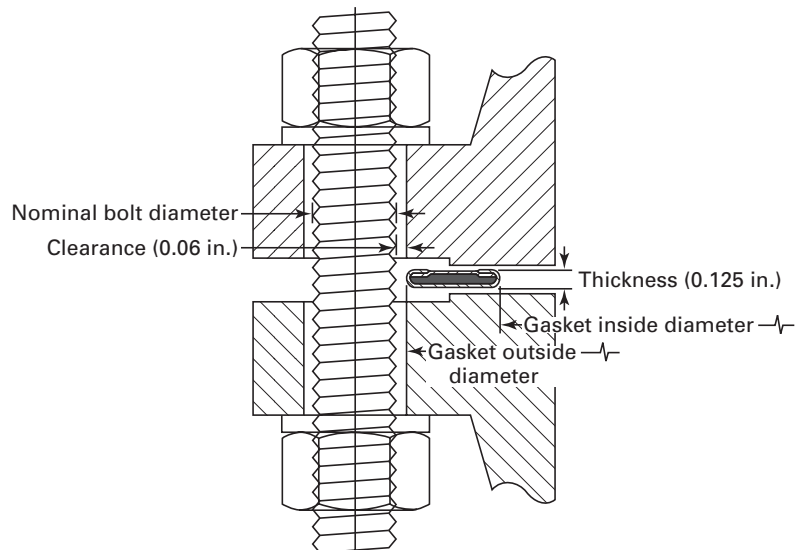

Flange Size (NPS)	Gasket Inside Diameter [Note (1)]	Gasket Outside Diameter by Class [Note (1)]				
		150	300	400	600	900 [Note (2)]
26	26.50	30.38	32.75	32.63	34.00	34.63
28	28.50	32.63	35.25	35.00	35.88	37.13
30	30.50	34.63	37.38	37.13	38.13	39.63
32	32.50	36.88	39.50	39.38	40.13	42.13
34	34.50	38.88	41.50	41.38	42.13	44.63
36	36.50	41.13	43.88	43.88	44.38	47.13
38	38.50	43.63	41.38	42.13	43.38	47.13
40	40.50	45.63	43.75	44.25	45.38	49.13
42	42.50	47.88	45.75	46.25	47.88	51.13
44	44.50	50.13	47.88	48.38	49.88	53.75
46	46.50	52.13	50.00	50.63	52.13	56.38
48	48.50	54.38	52.00	52.88	54.63	58.38
50	50.50	56.38	54.13	55.13	56.88	...
52	52.50	58.63	56.13	57.13	58.88	...
54	54.50	60.88	58.63	59.63	61.13	...
56	56.50	63.13	60.63	61.63	63.13	...
58	58.50	65.38	62.63	63.63	65.38	...
60	60.50	67.38	64.63	66.13	68.13	...

## GENERAL NOTES:

- (a) All dimensions are in inches.  
 (b) The gasket thickness tolerance is +0.03 in., -0.000 in.

## NOTES:

- (1) For gaskets NPS 26 through NPS 60, the outside diameter and inside diameter tolerances are +0.13 in., -0.000 in.  
 (2) There are no Class 900 flanges NPS 50 and larger.

**Table I-14 Jacketed Gasket Dimensions for ASME B16.47 Series B Flanges**

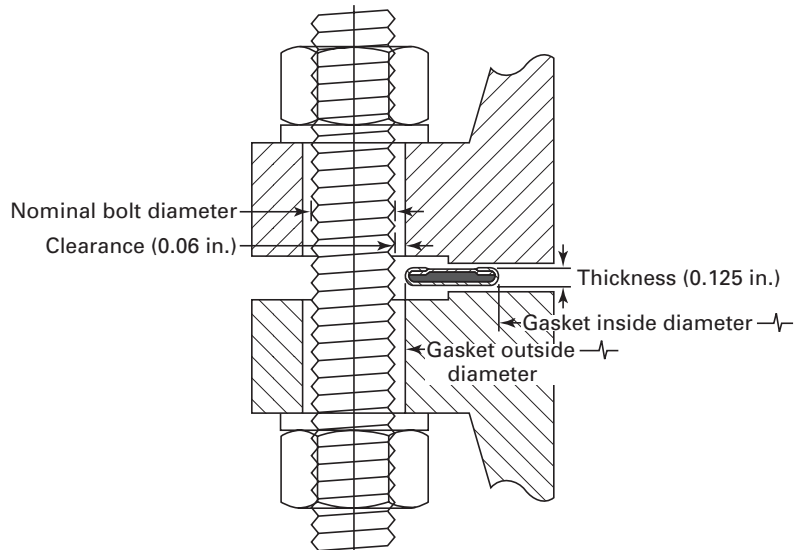

Flange Size (NPS)	Gasket Inside Diameter [Note (1)]	Gasket Outside Diameter by Class [Note (1)]				
		150	300	400	600	900 [Note (2)]
26	26.50	28.44	30.25	29.25	30.00	32.88
28	28.50	30.44	32.38	31.38	32.13	35.38
30	30.50	32.44	34.75	33.63	34.50	37.63
32	32.50	34.56	36.88	35.75	36.63	39.88
34	34.50	36.69	39.00	37.75	39.13	42.13
36	36.50	38.75	41.13	40.13	41.13	44.13
38	38.50	41.00	43.13	42.13	43.38	47.13
40	40.50	43.00	45.13	44.25	45.38	49.13
42	42.50	45.00	47.13	46.25	47.88	51.13
44	44.50	47.00	49.13	48.38	49.88	53.75
46	46.50	49.31	51.75	50.63	52.13	56.38
48	48.50	51.31	53.75	52.88	54.63	58.38
50	50.50	53.31	55.75	55.13	56.88	...
52	52.50	55.31	57.75	57.13	58.88	...
54	54.50	57.50	60.13	59.63	61.13	...
56	56.50	59.50	62.63	61.63	63.13	...
58	58.50	62.06	65.06	63.63	65.38	...
60	60.50	64.06	67.06	66.13	68.13	...

GENERAL NOTES:

- (a) All dimensions are in inches.
- (b) The gasket thickness tolerance is +0.03 in., -0.000 in.

NOTES:

- (1) For gaskets NPS 26 through NPS 60, the outside diameter and inside diameter tolerances are +0.13 in., -0.000 in.
- (2) There are no Class 900 flanges NPS 50 and larger.

## MANDATORY APPENDIX II REFERENCES

The following is a list of publications referenced in this Standard. Unless otherwise specified, the latest issue shall apply.

API Specification 6A-2004, Specification for Valves and Wellhead Equipment

Publisher: American Petroleum Institute (API), 1220 L Street, NW, Washington, DC 20005-4070

ASME B16.5, Pipe Flanges and Flanged Fittings<sup>1</sup>

ASME B16.47, Large Diameter Steel Flanges: NPS 26 Through NPS 60<sup>1</sup>

---

<sup>1</sup> May also be obtained from American National Standards Institute (ANSI), 25 West 43rd Street, New York, NY 10036.

ASME B36.10M, Welded and Seamless Wrought Steel Pipe<sup>1</sup>

ASME B36.19M, Stainless Steel Pipe<sup>1</sup>

Publisher: American Society of Mechanical Engineers (ASME), Three Park Avenue, New York, NY 10016; Order Department: 22 Law Drive, Box 2300, Fairfield, NJ 07007-2300

ISO 9001:2000, Quality management systems — Requirements

ISO 10423:2003, Petroleum and natural gas industries — Drilling and production equipment — Wellhead and christmas tree equipment

Publisher: International Organization for Standardization (ISO), 1 ch. de la Voie-Creuse, Case postale 56, CH-1211, Genève 20, Switzerland/Suisse

## NONMANDATORY APPENDIX A QUALITY SYSTEM PROGRAM

The products manufactured in accordance with this Standard shall be produced under a quality system program following the principles of an appropriate standard from the ISO 9000 series.<sup>1</sup> A determination of the need for registration and/or certification of the product

---

<sup>1</sup> The series is also available from the American National Standards Institute (ANSI) and the American Society for Quality (ASQ) as an American National Standard identified by a prefix "Q" replacing the prefix "ISO." ISO 9001 is listed in Mandatory Appendix II.

manufacturer's quality system program by an independent organization shall be the responsibility of the manufacturer. The detailed documentation demonstrating program compliance shall be available to the purchaser at the manufacturer's facility. A written summary description of the program utilized by the product manufacturer shall be available to the purchaser upon request. The product manufacturer is defined as the entity whose name or trademark appears on the product in accordance with the marking or identification requirements of this Standard.



INTENTIONALLY LEFT BLANK

# ASME B16.20-2007

ISBN-13: 978-0-7918-3116-8  
ISBN-10: 0-7918-3116-7



L03007